

CHAPTER 16 REVISION LIST

The following list of revisions will allow you to update the Lancair ES construction manual chapter listed above.

Under the "Action" column, "R&R" directs you to remove and replace the pages affect by the revision. "Add" directs you to insert the pages shown and "R" to remove the pages.

Page(s) affected	Current Rev. #	Action	Description
16-1 thru 16-38	0		
16-39	6	R&R	Enlarged NACA scoop template
16-40	6	R&R	Enlarged NACA scoop template
16-41 thru end	0		



Neo Aviation Inc. Copyright © 1999, Redmond, OR. 97756

16-i

Chapter
COCKPIT INSTALLATIONS

6/4-1-99

CHAPTER 16: COCKPIT INSTALLATIONS

REVISIONS

From time to time, revisions to this assembly manual may be deemed necessary. When such revisions are made, you should immediately replace all outdated pages with the revised pages. Discard the out dated pages. Note that on the lower right corner of each page is a "revision date". Initial printings will have the number "0" printed and the printing date. All subsequent revisions will have the revision number followed by the date of that revision. When such revisions are made, a "table of revisions" page will also be issued. This page (or pages) should be inserted in front of the opening page (this page) of each affected chapter. A new "table of revisions" page will accompany any revision made to a chapter.

ARROWS

Most drawings will have arrows to show which direction the parts are facing, unless the drawing itself makes that very obvious. "A/C UP" refers to the direction that would be up if the part were installed in a plane sitting in the upright position. In most cases the part shown will be oriented in the same position as the part itself will be placed during that particular assembly step. However, time goes on and changes are made, so careful attention should be paid to the orientation arrows. That old cartoon of the guy agonizing over the plans for his canoe, built one end up, one end down, should not happen in real life. Especially to you.

CONTENTS

1. INTRODUCTION
2. DRAWING LIST
3. SPECIAL PARTS, TOOLS & SUPPLIES LIST
 - A. PARTS
 - B. TOOLS
 - C. MATERIALS & SUPPLIES
4. PROCEDURE
 - A. SEAT BACK BULKHEAD
 - B. SEAT PANS INSTALLATION
 - C. FLAP PUSH ROD CLOSEOUT PANEL FOR SEAT
 - D. INSTRUMENT PANEL INSTALLATION
 - E. CENTER CONSOLE POSITIONING & SEAT BELT ATTACH POINT
 - F. PITCH TRIM INSTALLATION
 - G. PITCH TRIM ADJUSTMENTS
 - H. CONSOLE GLOVE BOX INSTALLATION (OPTIONAL)
 - I. SIDE ARM REST INSTALLATIONS
 - J. SHOULDER STRAP INSTALLATIONS
 - K. NACA DUCT INSTALLATIONS (COCKPIT VENTILATION)
 - L. PITOT / STATIC INSTALLATION - HOMEMADE PITOT TUBE INSTALL
 - M. AN5812 STANDARD PITOT TUBE INSTALLATION
 - N. STATIC PORT INSTALLATION

LANCAIR® 320FB

16-1

Chapter 16 REV. 0 / 11-1-91
COCKPIT INSTALLATIONS

1. INTRODUCTION

This chapter will address installations within the cockpit. Since one installation will usually have some effect on the next, it is again recommended that you read this entire chapter prior to performing these installations.

LANCAIR® 320FB

16-2

Chapter 16 REV. 0 / 11-1-91
COCKPIT INSTALLATIONS

2. DRAWING LIST

Drawing	Page	Title
16-1	16-7	Seat back bulkhead
16-2	16-8	Seat back patterns
16-3	16-10	Seat back and support stiffener
16-4	16-11	Seat pan
16-5	16-12	Seat pan fwd retaining lip
16-6	16-13	Seat pan cut out for control sticks
16-7	16-14	Seat close out panel
16-8	16-15	Instrument panel
16-9	16-16	Wood instrument panel pattern
16-10	16-18	Radio box support
16-11	16-19	Center console
16-12	16-20	Center console
16-13	16-21	Elevator trim arm attach
16-14	16-22	Console / instrument panel
16-15	16-23	Console / seat belt attachment
16-16	16-24	Console top
16-17	16-27	Elevator pitch trim
16-18	16-28	Elevator pitch trim breakdown drawing
16-19	16-30	Console glove box
16-20	16-31	Glove box
16-21	16-33	Side arm rest
16-22	16-34	Shoulder strap attachment
16-23	16-35	Shoulder strap attachment
16-24	16-37	NACA duct position
16-25	16-39	NACA duct layout
16-25	16-40	NACA duct layout (intentional duplicate of page 16-39)
16-26	16-41	Pitot tube (home made)
16-27	16-43	Pitot tube (commercial heated type)
16-28	16-44	Static port location
16-29	16-45	Static port installation

3. EQUIPMENT REQUIRED - SPECIAL PARTS, TOOLS & SUPPLIES

A. Parts

- Pre-molded seat bottom panels
- Pre-molded instrument panel (optional)
- Elevator pitch trim components - see figure 16-18, page 16-28.
- Hinge for glove box (optional)
- Shoulder straps (optional)
- NACA ducts and eyeball vents (optional)
- Pitot tube

LANCAIR® 320FB

16-4

Chapter 16 REV. 0 / 11-1-91
COCKPIT INSTALLATIONS

B. Tools

- drill motor
- drill bits: 1/4", preferably long shanked
#12
#40
- sabre saw
- small level
- tape measure
- rotary grinder (Dremel or equiv.)
- 5-10 lb weight bags (2)
- aluminum type hole punch (for instrument panel cut-outs)
- assorted files
- Unibit (cone shaped multiple diameter drill bit - very handy)
- pop rivet tool
- sharp matt or X-acto knife



Lancair International Inc. Copyright © 1991, Redmond, OR 97756

16-5

Chapter 16 REV. 0 / 11-1-91
COCKPIT INSTALLATIONS

C. Materials & supplies

- epoxy
- flox
- BID cloth
- micro
- sandpaper, assorted grit
- Duct tape or release tape
- MC or acetone for cleaning
- cardboard for templates
- 1/2" white Clark foam or 3/8" Nomex® honeycomb panel
- about a dozen pop rivets
- 1/4" phenolic material for hard points
- instant or hot glue

LANCAIR® 320FB

Lancair International Inc. Copyright © 1991, Redmond, OR 97756

16-6

Chapter 16 REV. 0 / 11-1-91
COCKPIT INSTALLATIONS



4. PROCEDURE

A. Seat back bulkhead

This is a relatively simple bulkhead that can be somewhat tailored to your seating position and desires. It is however recommended that the bulkhead be positioned so as to provide the maximum allowable room. If you desire less (i.e., more upright seating position) then use the upholstery cushioning to achieve a more vertical seat back angle (you can always pad it up but it's much harder to make it bigger once you have it locked in a position).

The seat back **MUST** attach to the top of the aft center spar cap. From that base point, it can be leaned back to an angle that suits you. We strongly recommend the position that places this bulkhead top position at a point that is approximately 1" aft of the aft deck roll over fwd face (as measured at the top longeron position). See figure 16-1.

SEAT BACK BULKHEAD

SIDE VIEW

Figure 16-1

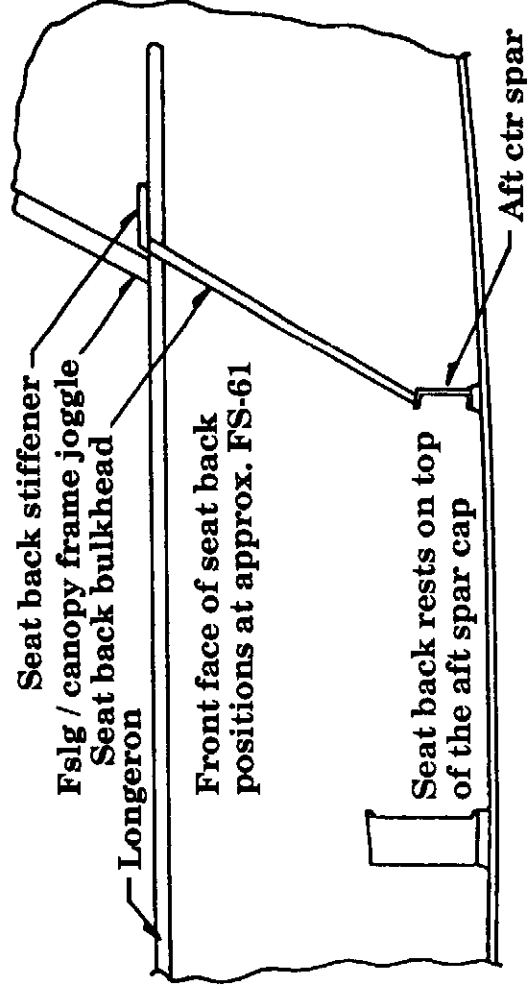

1. The seat back will be made from a bulkhead consisting of 1/2" white foam (or 3/8 Nomex® honeycomb) with 2 BID per side. Refer to Blueprint "B" for initial patterns for the seat back sides. Start with these patterns and make two cardboard templates. Make these templates wide enough that they can be overlapped and taped together when adjusted into the fslg. See figure 16-2.

2. Position the templates against the inside of the fslg along a line from the L.E. of the aft spar cap to an upper point about 1" aft of the intersection of top longeron & aft roll over brace. Adjust the contour as necessary to generate a good fit. Then tape the patterns together to generate the proper orientation of the side patterns and the proper width across the cockpit. This will serve well as an accurate pattern from which you can cut the actual bulkhead.

SEAT BACK PATTERNS

Figure 16-2

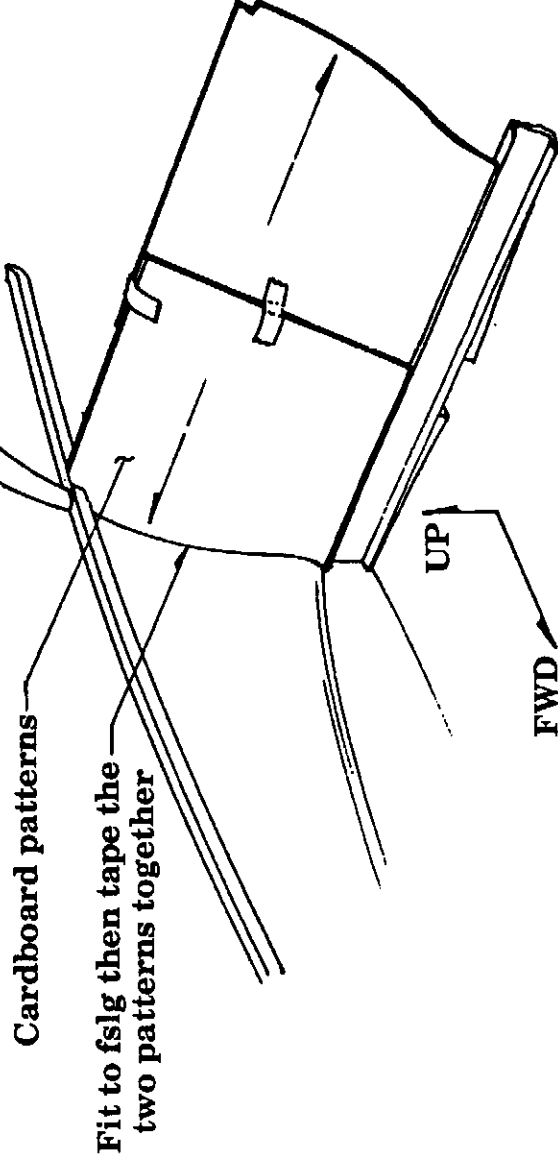

3. Cut the bulkhead out of either the 1/2" white foam or the optional Nomex® honeycomb panel. Establish 2 BID per side. Sand the bottom of the bulkhead panel to form a bevel so that it mates well with the top of the aft spar cap. The panel can sit aft of the leading edge of the spar cap by 1/4". This will provide the maximum possible length of the cockpit seating area. See figure 16-3.

4. Locate the center of the seat back and make a 2-3/4" wide cutout across the middle (at the bottom). This cutout should extend to what will be the top of your center console which is normally 11" above the floor of the cockpit as measured just in front of the aft spar.

NOTE: If you would like to make possible adjustments to the center console height, then simply make a cutout 10" up from the cockpit floor and you can easily cut additional material out at a later time when you've located the top of the console which can be adjusted up or down slightly for comfort. **REMEMBER** the dimensions listed above are measured up from the **FLOOR, NOT UP FROM THE BOTTOM OF THE SEAT BACK BULK-HEAD - THAT DIMENSION WILL BE LESS.** Use a tape measure and a small level (with the fslg levelled) to establish this position on your seat back.

With the fit established, cut back the foam slightly around the two sides and the bottom of the bulkhead and use epoxy/micro to pot the bulkhead into permanent position on the fslg. Be sure to properly clean and sand the sides of the fslg and spar cap first.

5. Next add a 2 BID (3" wide) tape around the perimeter (left side, bottom and right side) of the bulkhead fwd face. Add a similar 2 BID around the perimeter on the aft face (use a micro fillet to help the BID tapes transition over the top spar cap, see figure 16-3). Allow to cure.

6. From a piece of 1/2" white foam, cut and fit the top seat back stiffener. It will be made 3" wide and will sit on top of the seat back and on top of the longeron tops. See figure 16-3.

7. Use micro / epoxy to pot it into position and 2 BID to attach it to the seat back and fslg sides. Note that the top 2 BID attach tapes will be wider than normal and will thus extend across the full width of the top of this stiffener. The stiffener will thus end up with 4 BID across its upper surface. The aft or lower 2 BID attach should be 3" wide tapes.

8. After you have established the final size of the center cutout (at the console position), you must apply a 2 BID attachment tape around this perimeter. This can be applied after the console sides are attached and prior to attaching the console top. (Also see section on console installation).

LANCAIR® 320FB

16-9

Chapter 16 REV. 0 / 11-1-91

COCKPIT INSTALLATIONS

SEAT BACK AND SUPPORT STIFFENER CROSS SECTIONAL VIEW

Figure 16-3

Build this section on a bench, then bond into position and attach with the 2 BID tapes top and bottom.

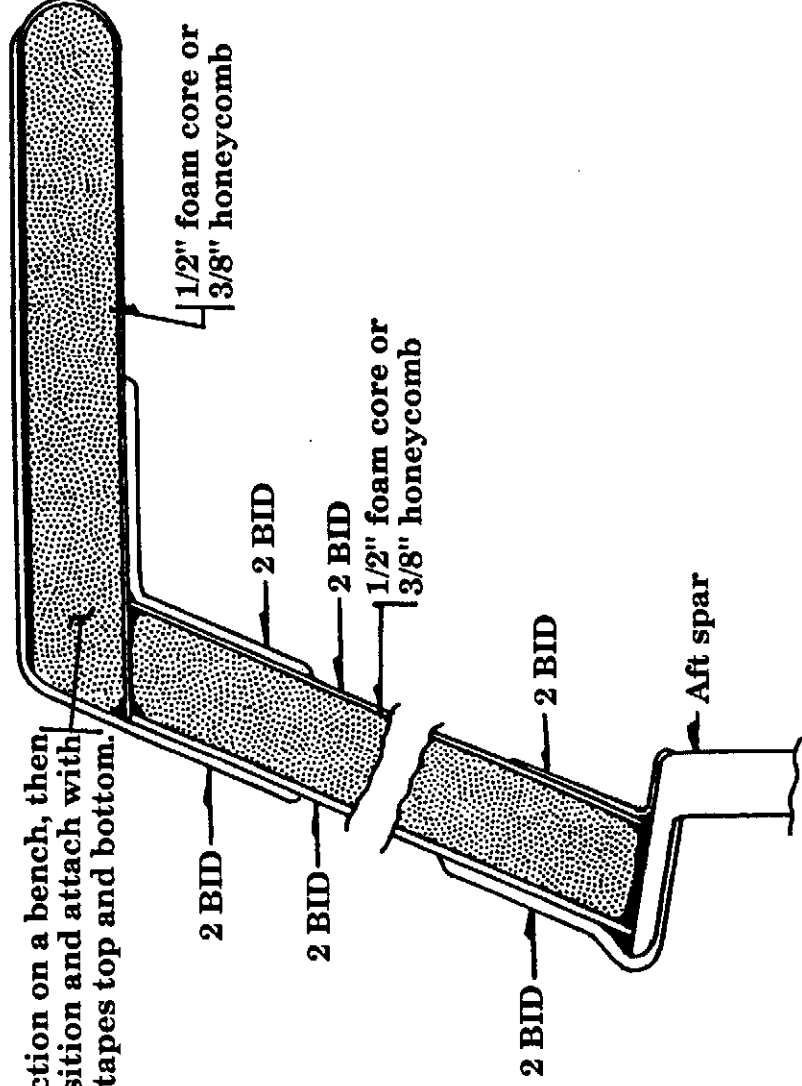

B. Seat pans installation

The seat pans are made from the supplied pre-molded seat bottom panels. These may be shipped as one piece which will then require splitting into two halves or they may already be split into two separate halves when you receive them. Also a closeout panel (removable) will be made to close off the flap push rod tubes, this is made from a flat panel.

1. First you'll need to mark a line on the fslg where the console sides will fit. You can also go ahead and make the console side (see section E., "Center console installation" in this chapter) and temporarily position them in the cockpit. We recommend that you install the seat pans before the console sides since you may wish to modify the console height but you'll need the seats installed with some temporary seat cushioning laid into position in order to make that determination.

SEAT PAN

FIGURE 16-4

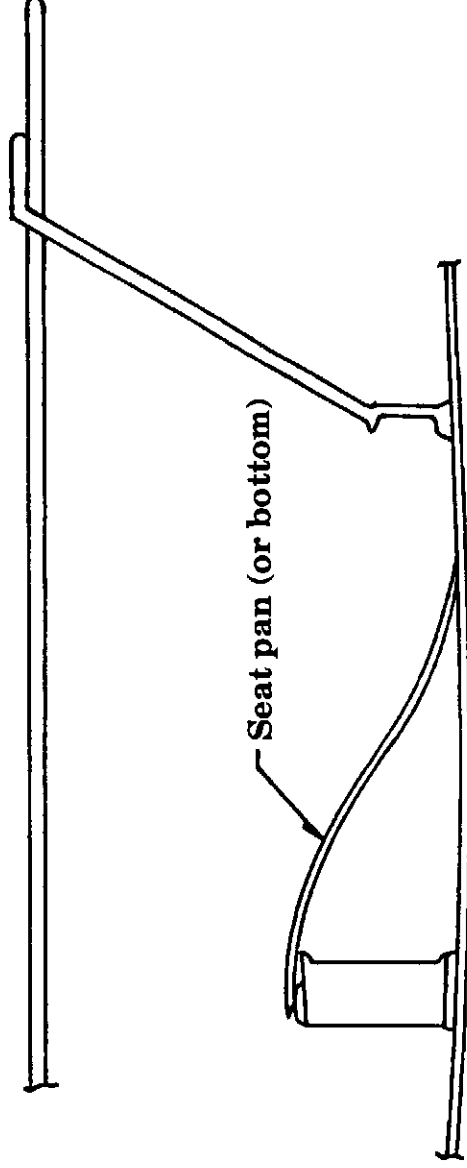

2. Cut the seat bottom to fit inside each side of the cockpit. You will have a little fwd / aft adjustment of the seat pan. This is a matter of comfort and also establishment of adequate clearance from the control stick and cross over weldment. The fwd end of the seat bottom will rest on the spar cap and the aft end will rest on the floor.
3. Trim the outbd fwd edges of the seat pans to clear the load transfer pads. Do not simply cut a notch in the seat bottom for the "web" of that load transfer pad since upon completion, the seat bottom will have to be slid aft about a half inch to be removed from its installation point.

SEAT PAN FWD RETAINING LIP

Figure 16-5

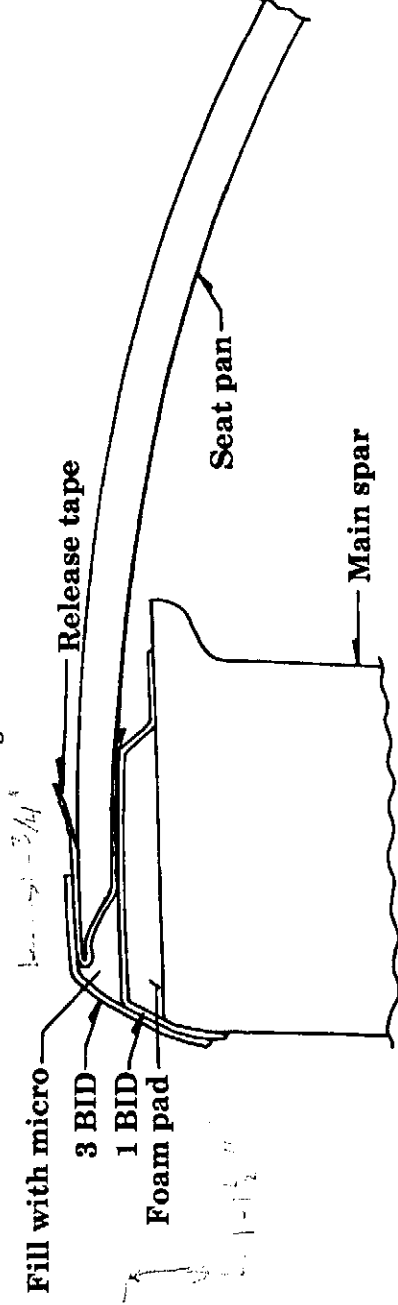

4. The aft end of the seat bottoms will sit on the fslg bottom. This bottom is slightly curved so the seat pan T.E. will not be a perpendicular cut but rather an angled cut which effectively makes for a longer seat bottom panel on the inbd side as compared to its outbd side. Adjust this cut until the seat bottom sits flat on the fwd main spar cap and also the fslg bottom.
 5. Make the cutout in the seat pan for the control stick. With the seat in position, make sure that you can rotate the stick throughout its full travel ranges and not contact the seat bottom. There must also be about 3/8" clearance under the seat bottom from the top of the stick crossover weldment at any point. This will sometimes require a foam pad or doubler which can be fibreglassed on top of the main spar cap thus raising the L.E. of the seat bottom and creating greater clearances for the crossover weldment. Usually a 1/4" doubler is all that is ever required. If this is needed, simply use micro to pot the 1/4" foam pad onto the spar cap and cover it with a 1 BID ply that laps onto the spar by 3/4" fwd and aft. See figure 16-5.
- WARNING:** You must sit in the cockpit and allow your body weight to rest on the seat pans in order to determine the positive clearance of the seat pan from the control system. There must be no contact of the seat pan onto the controls. Failure to properly establish this positive clearance could result in a system jam and possible loss of adequate controllability during flight.
6. The sides of the seat pans should have clearance from the sides of the fslg by about 1/2" and clearance from the center console by about 1/4".

7. With the seat pan and its position located, cover the fwd edge of the seat bottom with plastic tape. This should wrap about 3" on both the upper and lower surfaces. It will be used as a "release".

LANCAIR® 320FB

Lancair International Inc. Copyright © 1991, Redmond, OR 97756

16-12

Chapter 16

REV.

0 / 11-1-91

COCKPIT INSTALLATIONS

SEAT PAN CUT OUT FOR CONTROL STICKS

TOP VIEW

Figure 16-6

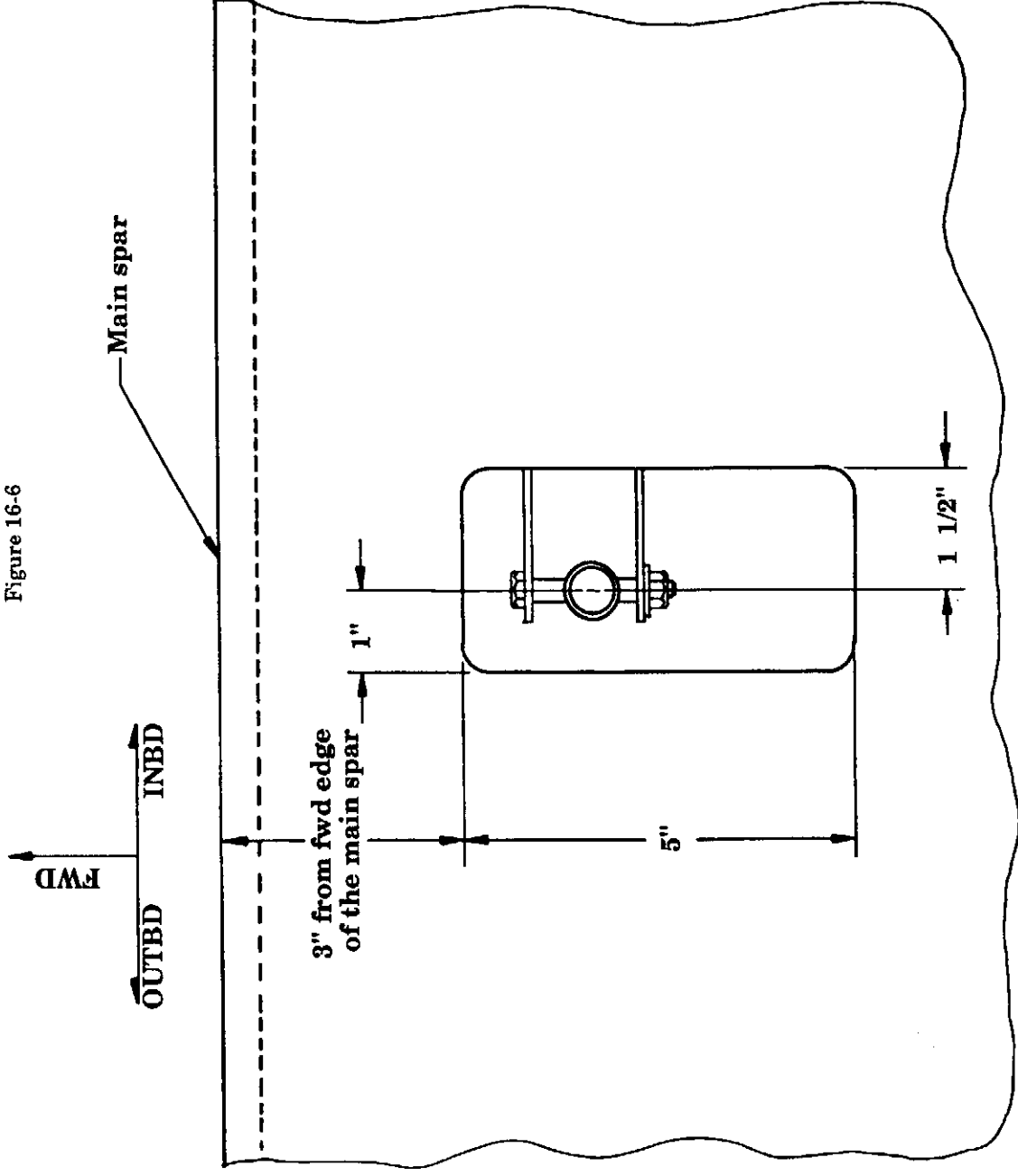

8. Place the seat pan in position and lay some weights on it to hold that position.
9. Apply a 3 BID layup across the fwd edge per figure 16-5. This will form a retention lip for the front of the seat pan. This BID layup should contact approximately 1-1.5" onto the spar and roll up over the seat pan L.E. by about 3/4". Allow to fully cure then remove the seat pan and trim the resultant retaining flange to size. This will form a fwd stop for the seat pan. An aft stop is not required.

LANCAIR® 320FB

Lancair International Inc. Copyright © 1991, Redmond, OR 97756

16-13

Chapter 16 REV. 0 / 11-1-91
COCKPIT INSTALLATIONS

C. Flap push rod closeout panel for seat

The flap push rods will require a simple flap panel that isolates them from the cockpit area and also provides a lower seat back panel.

1. Make a 1/4" foam panel with 2 BID on the outer side. It is generally easiest to simply use the plain, white foam material for this part since it requires some slight contouring on the back side for additional push rod clearance.

This panel should fit against the top spar cap / seat back and angle fwd to the floor panel. It should be angled fwd and positioned high enough on the seat back so as to provide positive clearance from the flap push rods during all ranges of motion. This area will be quite heavily padded with upholstery so a real smooth fit will not be required at all.

2. With this panel fitted and glassed with 2 BID on the outer side, remove it and sand the core material back to form additional clearance room where the flap push rod tubes will pass. Sand only about half of the foam core away through this central area thus leaving 1/8" of core. With this area sanded, add a 1 BID ply over it and establish a glass to glass bond on the top and bottom. See figure 16-7.

3. Wrap these pieces with plastic tape on the lower surfaces and position in the plane. Apply a small 3 BID strip along the junction of floor and panel that attaches permanently to the floor and forms a custom lip against the panel.

4. After cure, it is advisable to install one MS24694-S5 machine screw or an AN525 machine screw with one K1000-08 anchor nut to prevent the panel from possibly riding up and out of the retaining flange. See figure 16-7.

SEAT CLOSE OUT PANEL

SIDE VIEW

Figure 16-7

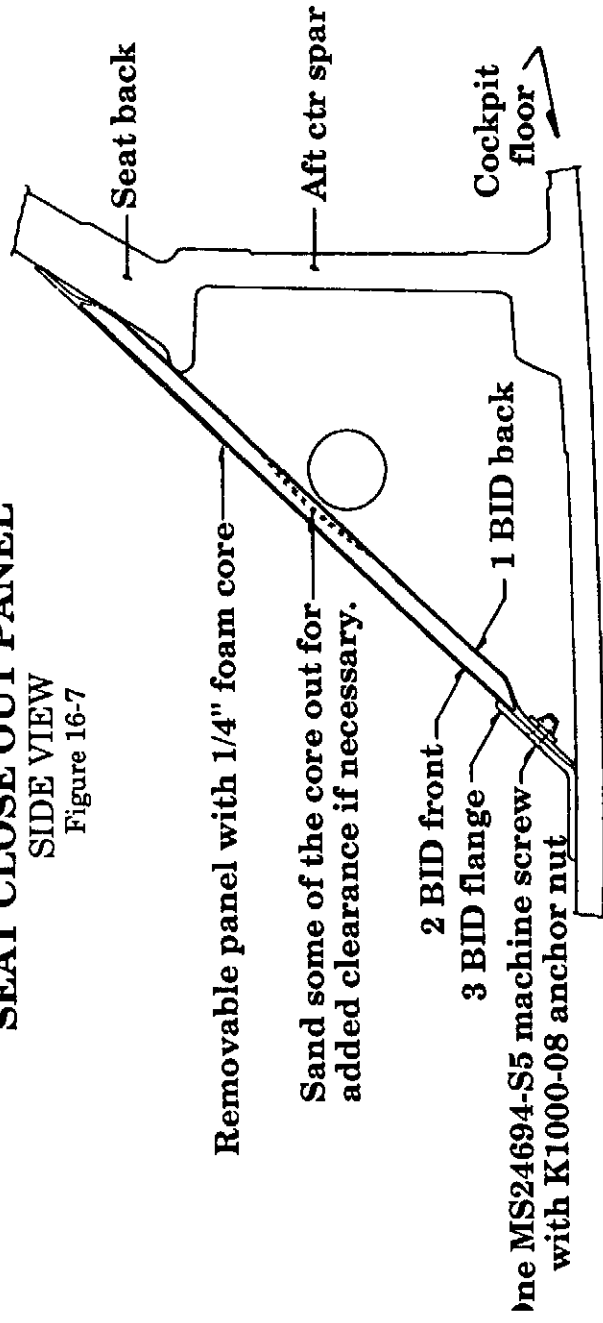

LANTAIR® 320FB

Lantair International Inc. Copyright © 1991, Redmond, OR 97756

16-14

Chapter 16 REV. 0 / 11-1-91
COCKPIT INSTALLATIONS

D. Instrument panel installation

The instrument panel is generally fiberglassed into the fs/g however it is not a structural bulkhead. Its position should be determined with respect to comfort and instrument room fwd of the panel.

INSTRUMENT PANEL

Figure 16-8

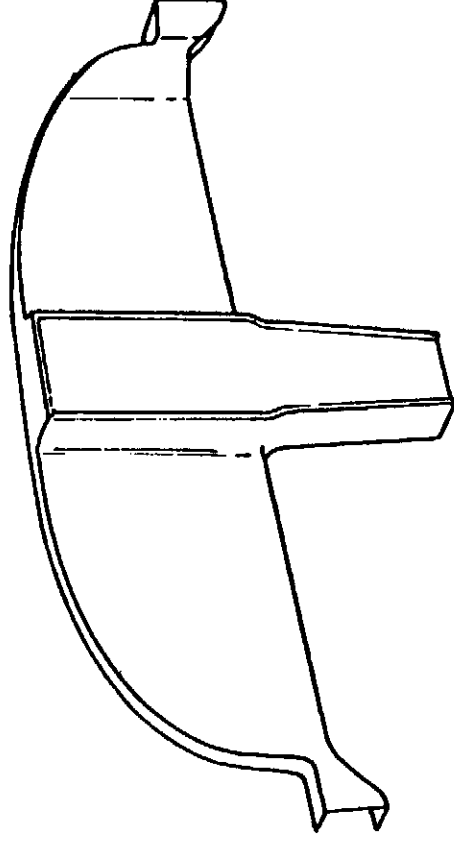

If you are installing our optional pre-molded instrument panel then the dimensions suggested will generally work well and the upper contours, when located off the top longeron, will easily fit under the canopy frame. If you are making your own instrument panel, it is recommended that you first simply lay the canopy frame over the aircraft in its approximate position. This will provide adequate contour information to allow you to check for necessary clearances between instrument panel and canopy frame. It is also possible to first install the canopy and frame prior to permanently installing the instrument panel, see chapter 17 "Canopy Installations". Either approach is acceptable.

1. The optional pre-molded instrument panel is designed to optimize all possible conditions and from all reports, it is well received. A simplified panel will be outlined below and can be easily fabricated. See figure 16-9.
2. The fwd / aft location for the instrument panel is dictated by several concerns. You should sit in the cockpit and feel comfortable with the location with regards to arms reach, knee room, etc. Also, the radio stack will require a minimum of 13" for most standard avionics however some radios and auto pilot boxes are as much as 14" deep. And thirdly, the upper left side of the panel will require careful attention regarding available depth due to the canopy slope.

LANCAIR® 320FB

Lancair International Inc. Copyright © 1991, Redmond, OR 97756

16-15

Chapter 16

REV.

0 / 11-1-91

COCKPIT INSTALLATIONS

3. If you are fabricating your own panel, it is recommended that you follow the suggested dimensioning and make a pattern that is sawed out of a piece of 3/4" particle board or equiv. You can trial fit this pattern into position. Cover the pattern with plastic tape and apply a 5 BID layup over it. The BID should roll over the edge and extend the full 3/4" to form a stiffening lip around its perimeter. Arrange the BID in all slightly different weave orientations so as to aid in overall stiffness. See figure 16-9.

WOOD INSTRUMENT PANEL PATTERN LAYOUT SIMILAR TO THE OPTIONAL PRE-MOLDED PANEL

Figure 16-9

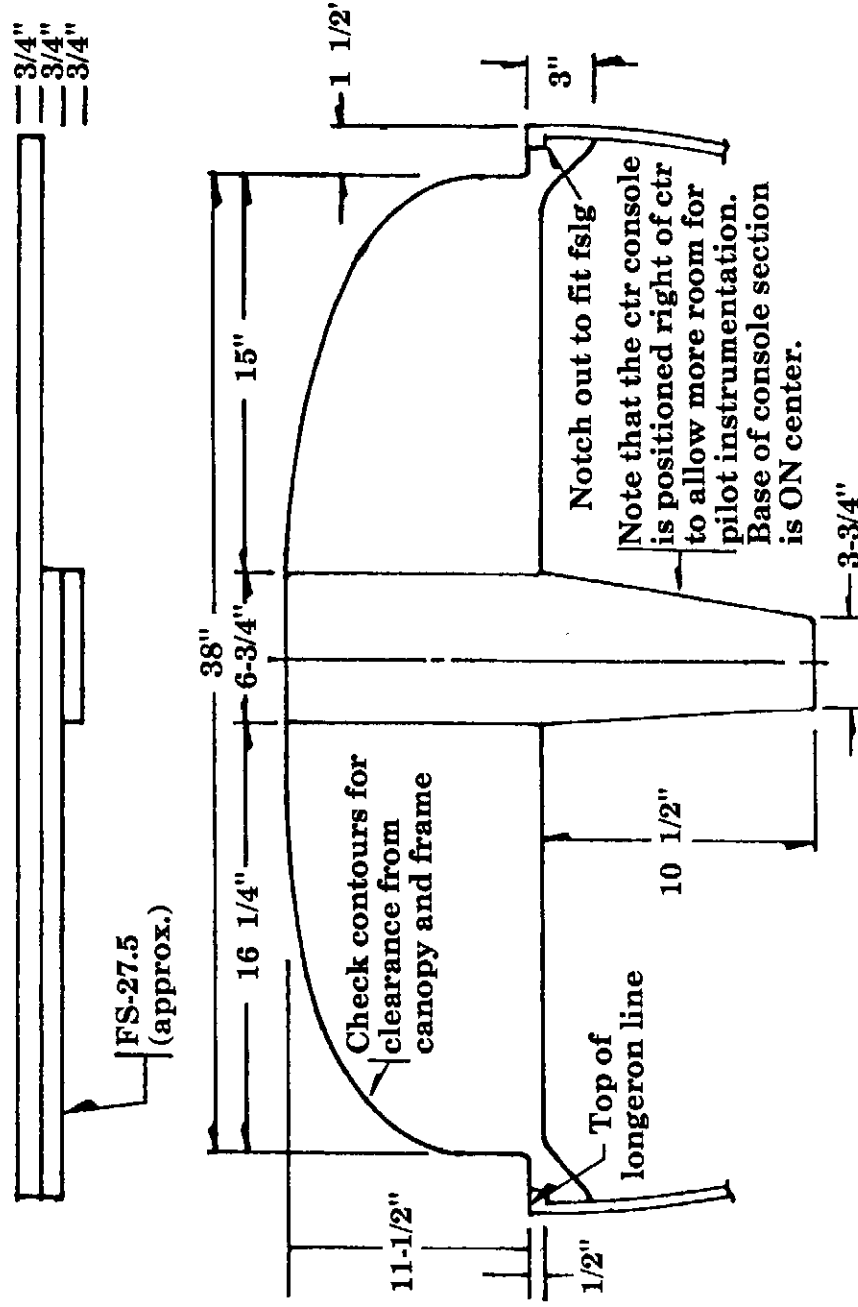

4. Fit the panel into the fslg. The lower center portion of the vertical console should rest on the top of the spar cap. The console sides will later be installed up to this vertical console.

5. There is generally a little extra width to the pre-molded panels. This will allow for trimming to fit against the longerons. The panel can be notched to fit against the longerons. The outboard sides of the panel have a horizontal portion that can be aligned to the top of the longerons. This is acceptable however if knee room permits, a slightly lowered panel will afford better gyro installation room. Be sure to allow for upholstery thicknesses when making determinations for the vertical height of the instrument panel and the resultant knee room.
- One of the nice advantages of the Lancair cockpit is the leg positions available. We like to fly with our feet back and resting against the angled portion of the sub floor. This will obviously require the ability to rotate your knees up and past the panel bottom so do leave room for that movement.
6. Also a slight lean will provide additional room for long gyros, etc., 2° - 3° is generally acceptable.
7. With the panel location selected, attach it with 3 BID tapes on both left and right fslg sides (fwd and aft faces of the panel) and at the bottom center onto the spar cap with similar 3 BID tapes. Sand the primer coat off the pre-molded panel prior to attaching the BID tapes.
8. When it comes time to start installing instruments, etc., a standard aluminum type hole punch will work for the standard sized instrument holes. We've used the type that have a 5/8" center arbor bolt with a matched die punch plate that fits in the front and back. You then use two big wrenches to tighten the nut on the 5/8" bolt and punch the hole through. This will be considerably harder than with a conventional aluminum panel but it works satisfactorily. Use a drill and / or a rotary tool cutter for the other cut outs.
- The cone shaped multiple diameter drill bits (Unibit) work extremely well in producing beautiful smooth holes.
9. The gyro side of the instrument panel requires a small brace to support the panel face due to the weight and length of the gyros. This can be a thin wall steel tube (5/16" diameter) that is flattened out on the ends and then bent to the required contour to fit under the dust cover. Secure the brace with a pop rivet at the instrument panel and either 2 pop rivets or small machine screws at the lip of the fwd deck. The radio stack will also require supports on each side of it that attach to the sides of the nose gear tunnel, these will add additional rigidity. The right hand side of the panel usually does not require any supports.



10. An additional means of supporting the radio boxes at the panel face is to make two small phenolic blocks that will fit between the box sides on the inside of the panel itself (pre-molded panel). Drill and tap the phenolic pieces for 6-32 flat head machine screws. These pieces will only be about 3/16" thick so you'll need very short screws. Screw the phenolic pieces to the radio box, add some epoxy / flox to the mating surfaces and place the radio box unit into position to cure. After cure, simply remove the screws and the phenolic pieces will be bonded into perfect position. This will anchor the front of the radio stack nicely to the instrument panel. The radio boxes should all be screwed or riveted together to form a single unit, this can be accomplished by attaching a simple strap along each side of the radio box stack. (Most radio boxes have provided room for such screw attachments at the panel face areas.) See figure 16-10.

RADIO BOX SUPPORT CUT AWAY VIEW

Figure 16-10

Aluminum support straps.
Secure to boxes with either
rivet or machine screw.

Phenolic block is screwed to
radio box prior to positioning.

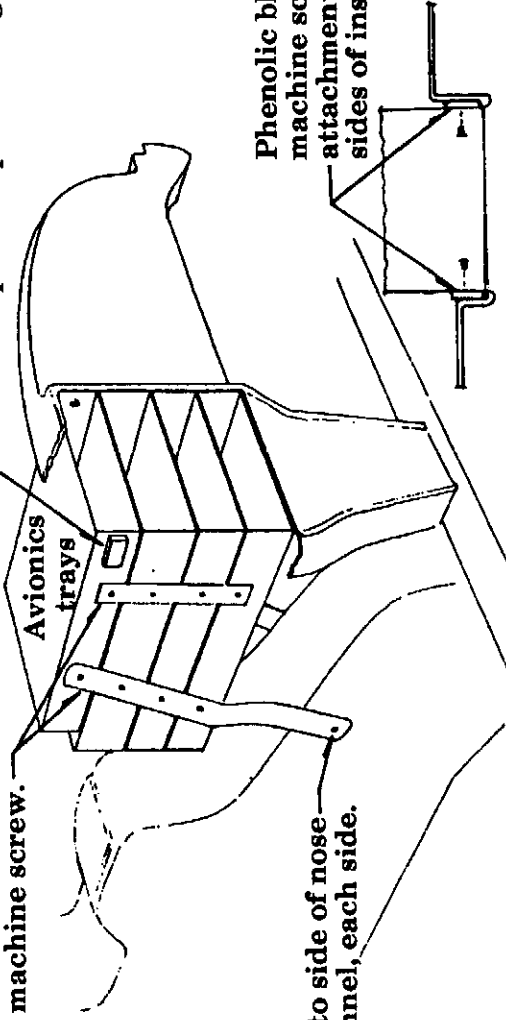

Secure to side of nose
gear tunnel, each side.

Phenolic blocks with
machine screw
attachment. Bond to
sides of instr. panel.

Center console installations

There are two basic installations involved with the center console:

1. Inboard seat belt attachments,
2. Pitch trim installation.

In addition we suggest a center glove box since there is available room and it's nice to have a place for storage of pens, scales, tie downs, flash lights, etc.

CENTER CONSOLE

3/4 VIEW, OVERALL

Figure 16-11

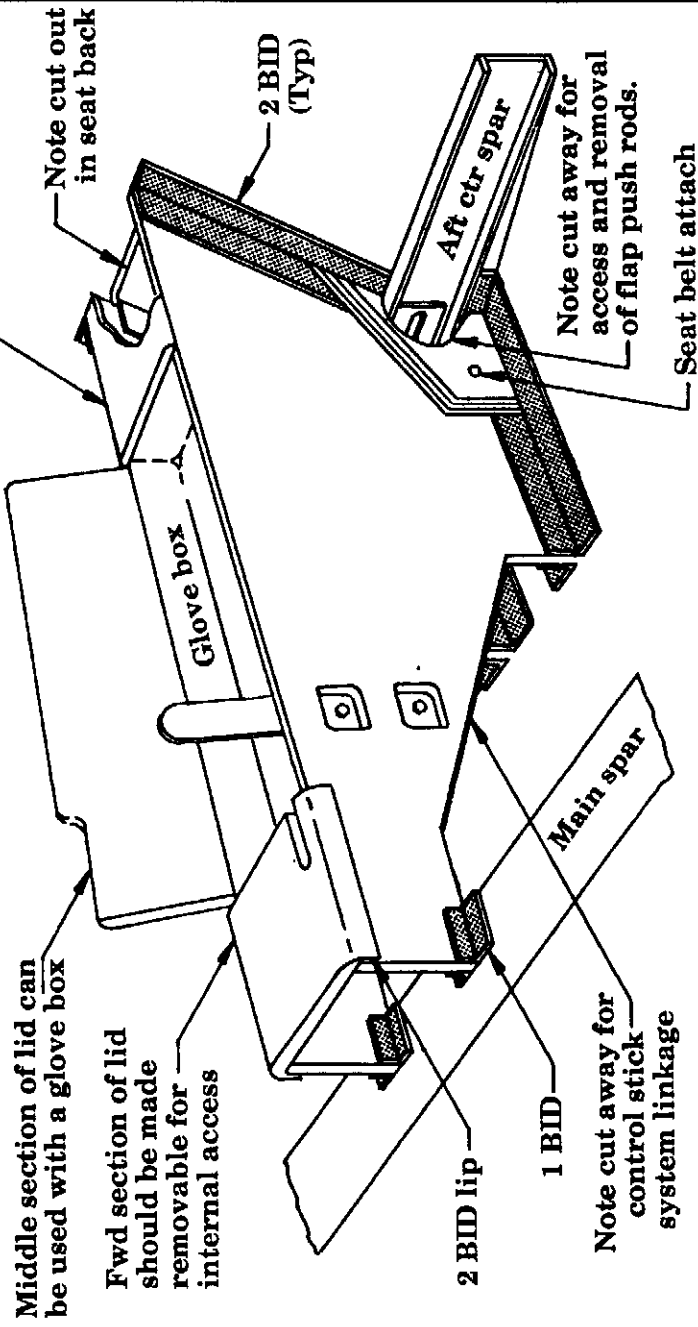

E. Center console positioning & seat belt attach point

The position will allow for your individual comfort. We generally suggest that the console have a narrow aft section which provides for more seat width. And a fwd width such that it blends into the vertical component of the instrument panel.

1. Select a vertical height for the console sides by sitting in the cockpit with approximately the amount of upholstery that will be used. You'll want to sit fairly close to the top of the canopy for the best visibility. This can be estimated with some accuracy by simply placing the canopy frame on the plane in approximate position and having someone carefully lay the canopy on top of it while you sit inside. (You can also install the canopy frame and canopy first, see chapter 17.)

2. We selected a maximum height of 11" for our center console and it seems comfortable. You may want to simply use that dimension.
3. See Blueprint "M" for the full size console pattern. Make this out of cardboard and fit it to your airframe and seat back angle. When completed, make the two sides out of 1/4" core with 1 BID per side. Insert the three 1/4" phenolic hard points into the left side and the one hard point into the right side panel per blueprint "M", see figure 16-12.

CENTER CONSOLE
SIDE VIEW, ALSO SEE BLUEPRINT "M"

Figure 16-12

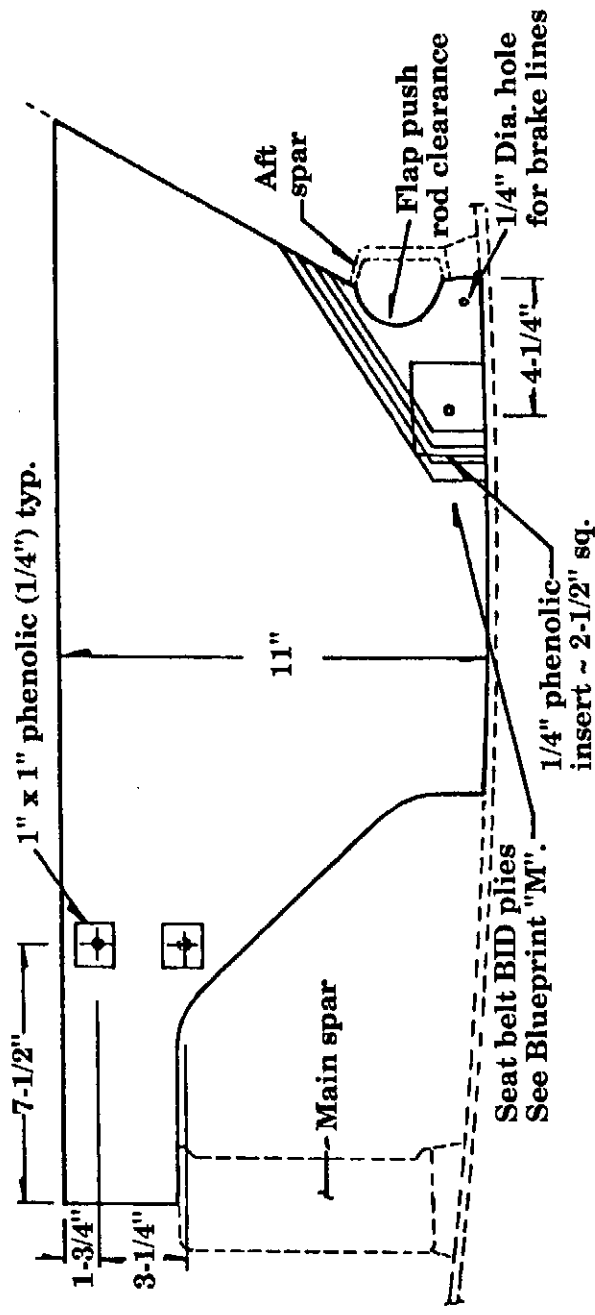

4. The two phenolic hard points for the seat belt attach are typical installations and can be inserted from either side of the panels.
5. The two phenolic hard points for the pitch trim system are unique in their installation. First locate their positions on the inside surface of the left panel.
6. Next attach them with a little epoxy / flox around their edges only. Then apply a 2 BID patch over them, contact at least 1" all around onto the inner surfaces of the panel. Allow to cure.

- Next use a matt knife to carefully cut the core material away from the outside surface and form a smooth bevel that transitions down to the surface of the phenolic that has been attached. Close this out now with a 2 BID patch that lays down into the cut outs. This will provide a recess for the bolt heads on the outside of the console side, see figure 16-13.

ELEVATOR TRIM ARM ATTACH CROSS SECTIONAL VIEW

Figure 16-13

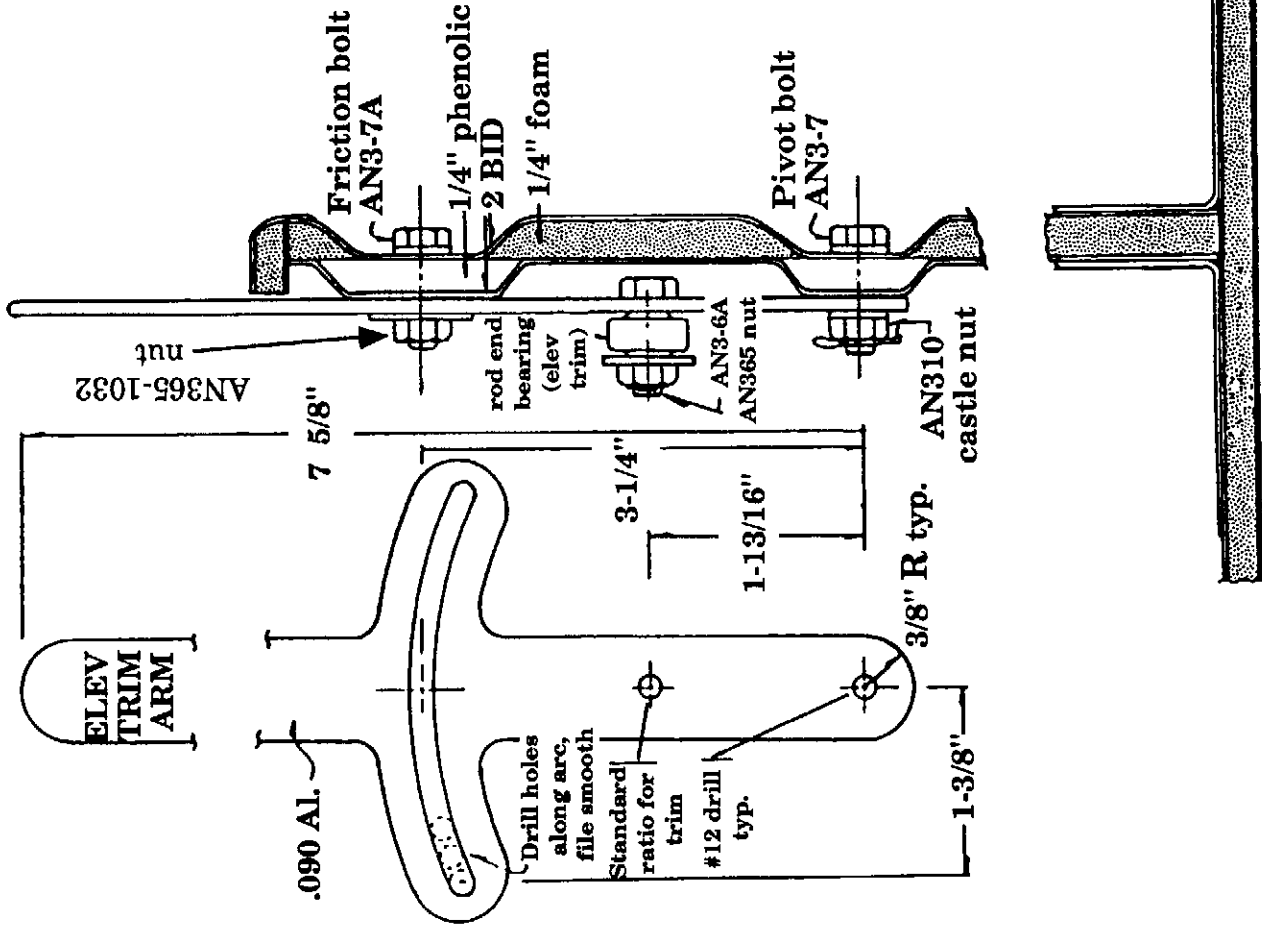

NOTE: When establishing the width of the console, be sure to leave enough room for the elevator pitch trim system installation, see figure 16-17. This will generally require 7/8" minimum clearance from the inner left side wall to the edge of the elevator push rod tube as measured at its widest point on the radius.

8. Make a final fit of the console sides into the cockpit. Mark the top of the console at the instrument panel (fwd end) and at the seat back (aft end).
9. Trim out the center portion of the instrument panel that lays between the two console sides, see figure 16-14. This is a good location to run wires through so you'll want the access. You can also trim the seat back panel to the top of the console sides if desired, but that's not essential. The seat back should however be trimmed so that its cut out aligns with the inner surfaces of the console sides. This will make the application of a bonding BID tape much "cleaner" and easier.

CONSOLE / INSTRUMENT PANEL

Figure 16-14

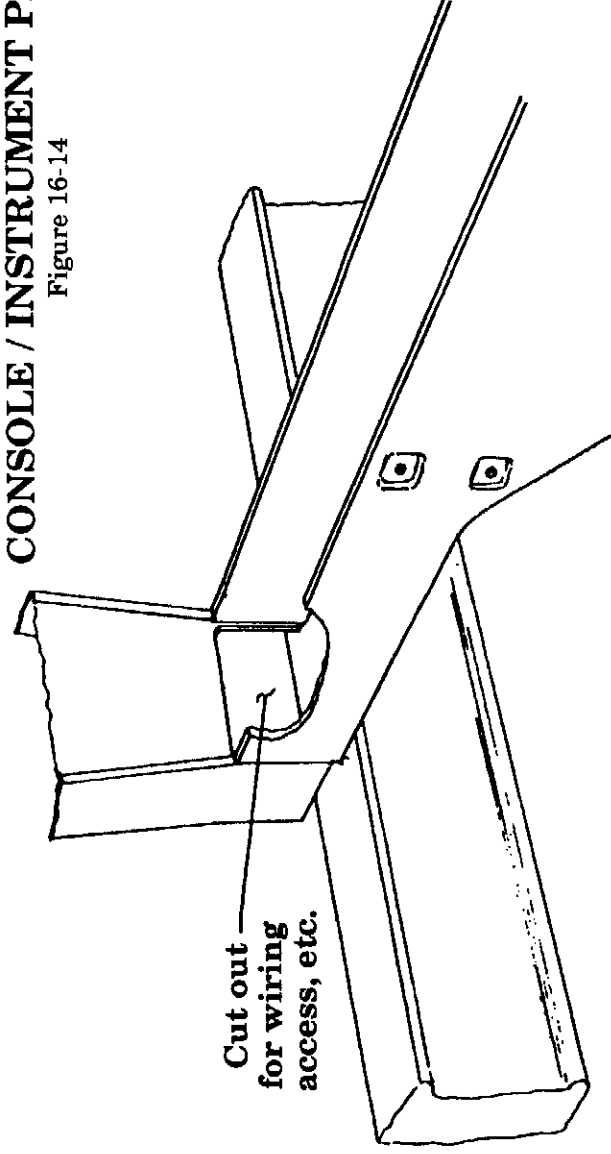

10. Now bond the center console into permanent position using micro / epoxy to pot it in position. Allow to cure.
- NOTE:** The phenolic pieces for the seat belt attachment should be potted into position but no additional BID tapes should be applied until after the console is bonded into position in the cockpit.
11. See figures 16-11 and 16-15 for the attach BID schedules of the console sides. Add the 2 BID around the entire perimeter on both the inside and the outside surfaces.

LANCAIR® 320FB

Lancair International Inc. Copyright © 1991, Redmond, OR 97756

16-22

Chapter 16 REV. 0 / 11-1-91
COCKPIT INSTALLATIONS

**CONSOLE / SEAT BELT ATTACHMENT
CROSS SECTIONAL VIEW**

Figure 16-15

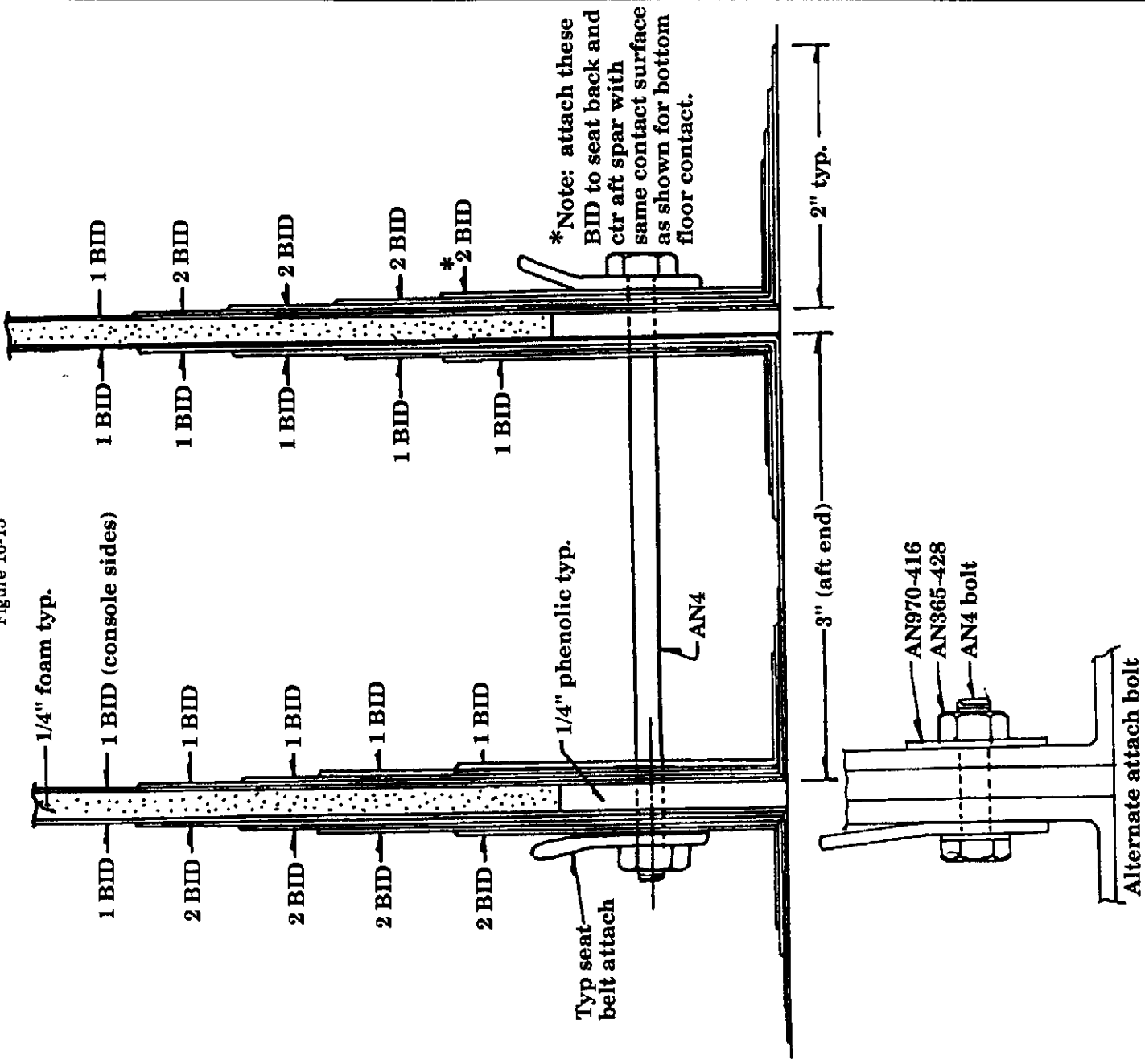

Lancair International Inc. Copyright © 1991, Redmond, OR 97756

12. Add the additional BID schedules along the aft floor and against the aft spar web which will create the seat belt hard point. This additional (and quite substantial) BID ply schedule can be added immediately after the initial 2 BID are applied. In fact it's a good idea to do that all at one time rather than allow the 2 BID to cure first.

You'll find it easiest to make a slit in the BID plies where they fit into the corner formed by the floor, console and aft spar web. See Blueprint "M".

13. When cured, drill the 1/4" hole for the seat belt attachment bolt. It is recommended that one through bolt be used instead of two smaller bolts. This has a structural advantage of reducing the bending moment on the bolt. This will require hole alignment from left to right side when drilling. Use a long 1/4" drill bit to achieve the alignment. Since the console width dimensions will vary from one builder to another, we are unable to supply this through bolt in standard airframe kits. If you use two smaller bolts, be sure to install an AN970-4 area washer between the bolts and the inner sides of the console sides. See figure 16-15.

14. Make a console top from 1/4" foam with 1 BID per side. Make a one piece console top to begin with. This top can then be cut into three segments. See figure 16-16. The aft segment should be bonded permanently to the console sides and seat back. Use 1 BID to make this attachment.

CONSOLE TOP

Figure 16-16

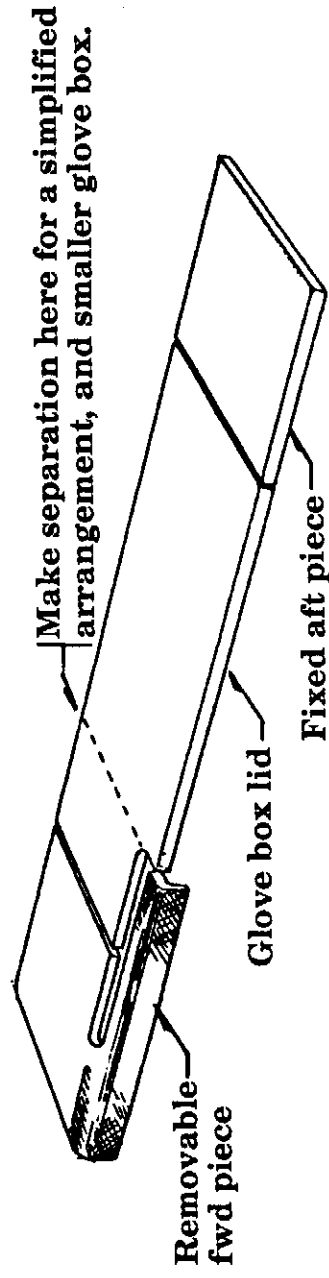

15. The middle portion can be made as a glove box lid, see section "H" in this chapter, "Console glove box installation".

16. The fwd portion of the console top should measure approximately 4" to 6" in length and should be made removable. To accomplish this, place plastic tape on the outer sides of the console and position the fwd top piece. Lay a 2 BID ply over the edges and extend them down about 1/2-3/4" past the top of the sides. Allow to cure. This will form a custom "lip" which will hold the part in position. It will require a slot cut into it for movement of the pitch trim handle but that can be done later as required for clearance. You'll want to be able to remove this panel for access to controls and wiring.

LANCAIR® 320FB

16-25

Chapter 16 REV. 0 / 11-1-91
COCKPIT INSTALLATIONS

F. Pitch trim installation

The pitch trim system is a very simple and effective spring loaded unit. Some builders have installed an electric servo system to drive it, but we prefer the simple mechanical arm.

1. Make the control arm per figure 16-13. (This is supplied in the Builder Hardware Options Kit.)
2. Next select the nylon attach block and saw it in half as shown in figure 16-17. This will allow positioning onto the fwd push rod of the elevator linkage.
3. Assemble the spring rod per figure 16-18. This will require cutting the spring into two equal length pieces. Drill and tap one end only for the M34-14 rod end bearing. Use the washer and cotter key to "set" the springs properly onto the shaft.
NOTE: It is generally best to make a quick "fit check" of the installation into the console. If space allows, it is then best to position the springs & nylon block at the extreme opposite end of the rod end bearing. This will help with alignments throughout the small rotational arc created when the control arm is pushed from fwd to aft.
4. Mount the assembly onto the fwd elevator push rod using the two AN3-17A bolts and AN365-1032 lock nuts.

WARNING: Do not overtighten the bolts that mount the nylon block. The block should only be tightened enough to firmly set the block in position. Over tightening could break the nylon block thus loosening all pitch trim.

ELEVATOR PITCH TRIM

Figure 16-17

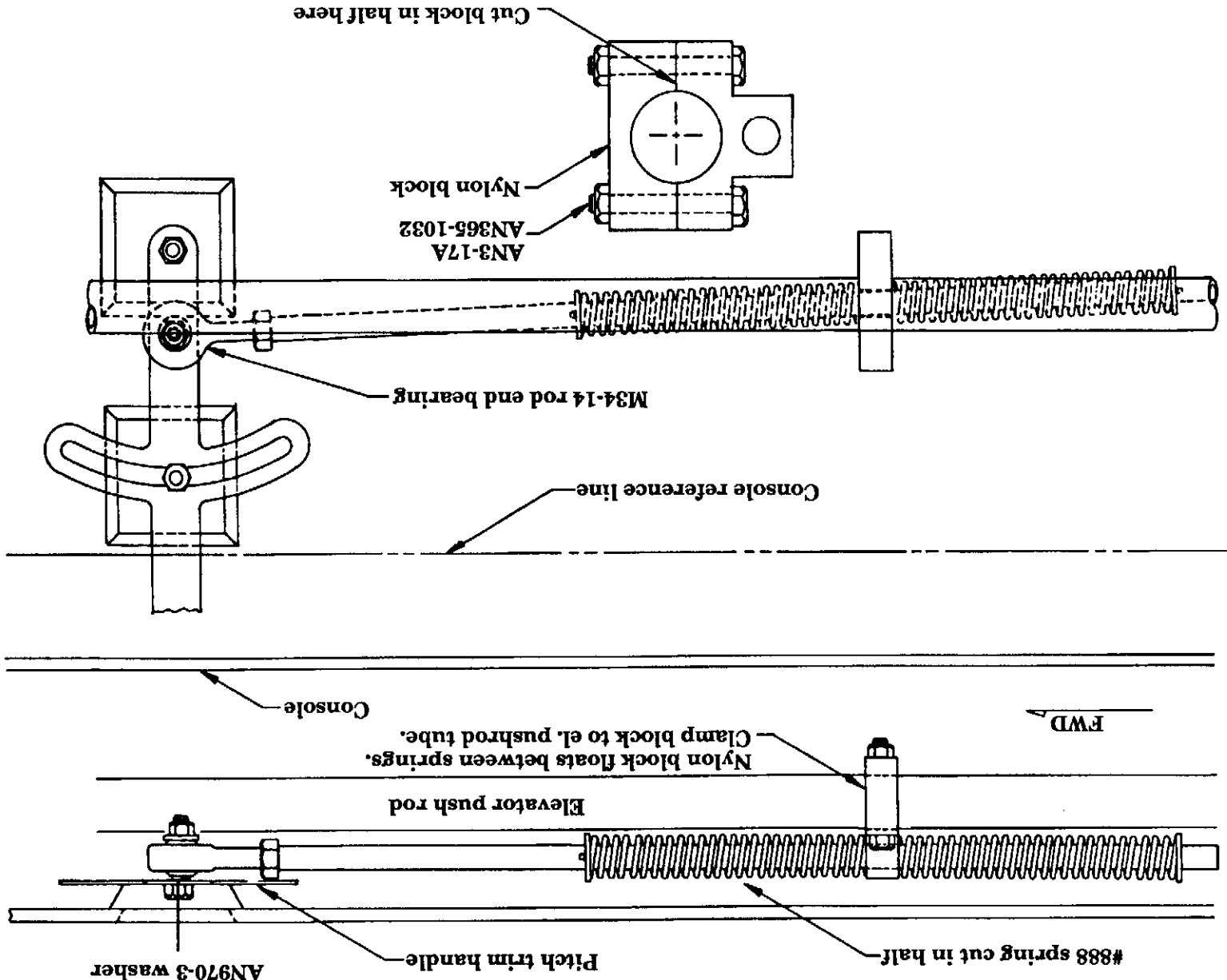

ELEVATOR PITCH TRIM BREAKDOWN DRAWING

Figure 16-18

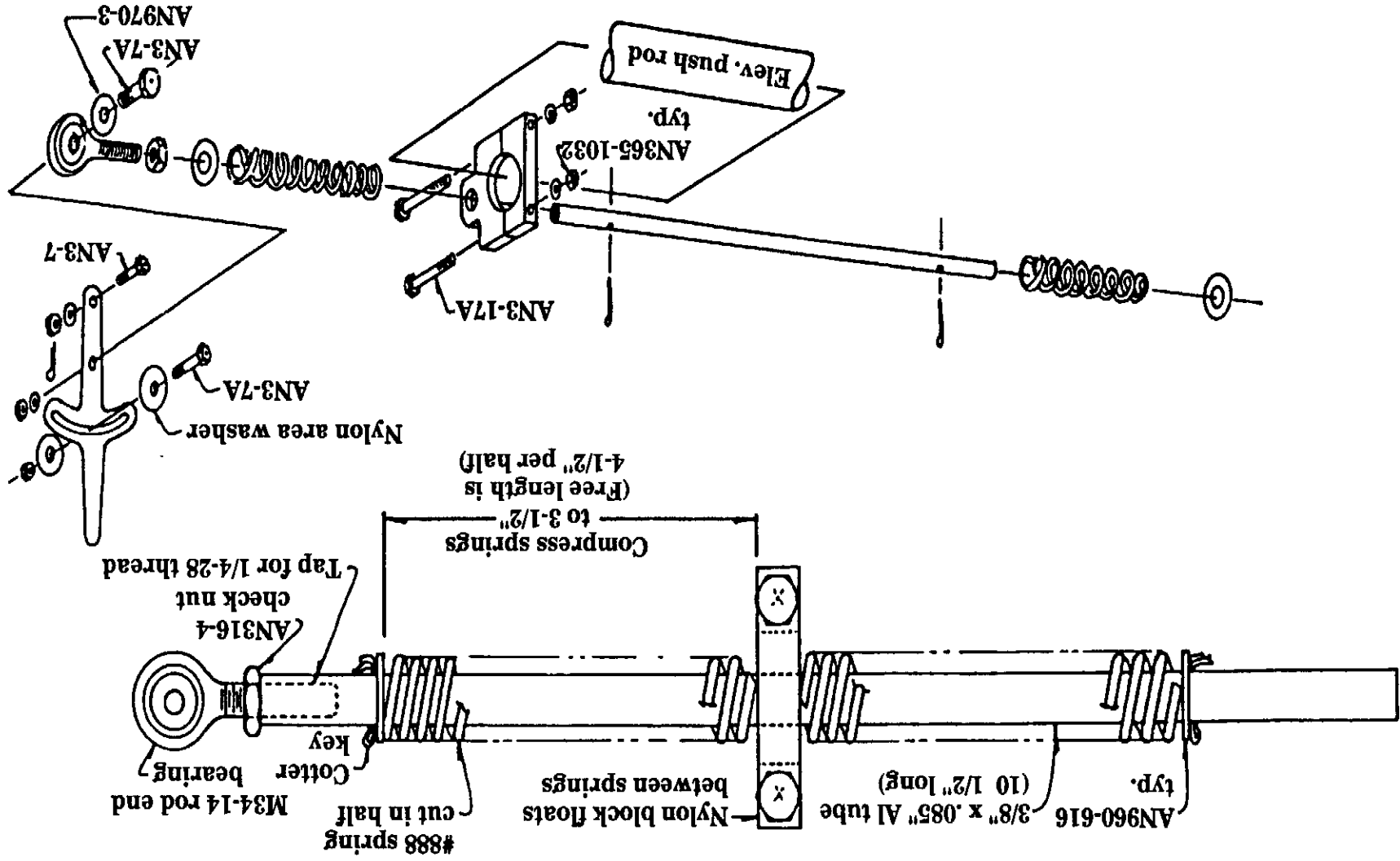

G. Pitch trim adjustments

1. The final adjustment of the trim system will be made based on flight conditions. However, as a preliminary position, set the spring assembly on the push rod such that when the trim arm is vertical, the elevator is slightly T.E. UP. (I.e., about 3-5° up elevator with the trim arm vertical in the cockpit.) This will be a good starting position.
When properly positioned, there should be sufficient travel to trim the plane in all flight conditions. Small adjustments can be made by simply sliding the nylon block fwd or aft on the elevator push rod. Make very small adjustments, a 1/8" position change of the nylon block on the push rod will have very significant results.
2. Also check the rotational position of the nylon block and the connected spring assembly. By rotating the nylon block slightly up or down (around the push rod), the assembly can be set into position that is most favorable for a smooth operation.
3. Set the tension on the two bolts that hold the control arm such that it moves smoothly but with considerable resistance. The two nylon area washers should be spaced on either side of the top "tension" bolt. To check the tension, set what you think is correct and then move the control stick through about 60% of it's full travel motion. The trim arm should not move. If you set it at an elevator neutral position, you should be able to pull about 3/4 of the elevator up motion without moving the trim arm at all. If you can pull full up elevator, then that's better yet. If you get a little movement of the trim arm with extreme up elevator, then that is generally acceptable as well. Normal flight conditions will not see that kind of travel extreme from a trimmed position and if it did occur, you would simply pull the trim arm slightly which would not cause any problems other than requiring a re-trim however if it resulted in a sharp snap movement of the stick then adjustments must be made to avoid such a condition as it would be detrimental to smooth, safe flight.

H. Console glove box (optional installation)

As mentioned previously, you do not have to install a glove box but the Lancair does have room for one and they're real handy to have.

1. With the location of the glove box selected, you should already have the part that will form the lid. See section "E" of this chapter. (After you have completed this installation, go back and fill the perimeter of the lid with epoxy / micro to close out the bare foam edges.)
2. It is perhaps easiest to make a "plug" of the actual cavity that you have chosen to become the glove box tray. This can be made from a piece of wood which has been covered with plastic tape as a release. See figure 16-19.

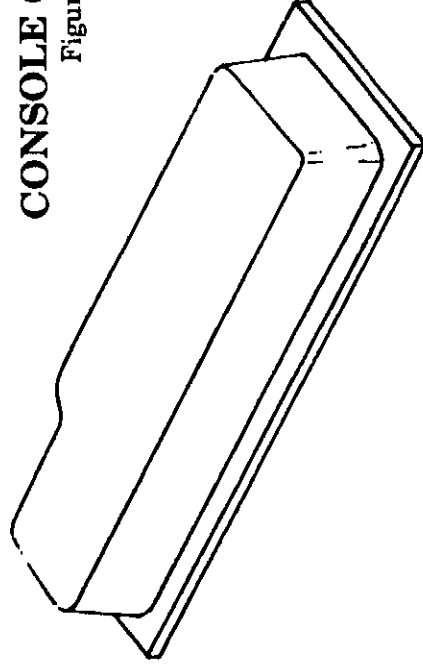

CONSOLE GLOVE BOX

Figure 16-19

The glove box "plug" should be made smaller than the inside width of the box by about 3/16". This will allow for the thickness of the BID and a little clearance room.

Calculate the available depth of the box so that it will not hit any of the controls. Also note that a "jog" will be required at the left, fwd end where clearance from the pitch trim arm will be required.

3. With the plug covered with plastic tape, lay 3 BID over it. Allow the 3 BID to roll out at the base of the plug, this will be the top of the tray and thus form a lip for the tray to hang from. You will later trim the lip to not extend past the outside edges of the console. Allow to cure then lift it off the plug. You now have a custom tray.
4. With the actual tray fitted into the console, cut two small sections of hinge - about 2" long each. Drill several holes into one side of the hinge section only.
5. Scrape away the core in the lid where the hinge pieces can be pressed in position. Also do the same for a position into the right side of the console to accept the other hinge halves.

LANCAIR® 320FB

Lancair International Inc. Copyright © 1991, Redmond, OR 97756

16-30

Chapter 16

REV.

0 / 11-1-91

COCKPIT INSTALLATIONS

6. Cover the undrilled hinge halves with plastic tape as a release.
7. Fill all four of the slots with epoxy / flox. Press the hinge halves that are drilled with holes, into the top panel and at the same time press the remaining sides that are covered with plastic tape into the console sides. Wiggle it down into a good aligning position, add a couple of weights to hold it in place and let it cure.
Note that the tray will require a couple of clearance cuts around the areas where the hinges will be positioned.
8. After cure, you can remove the lid by pulling straight up and releasing the hinge "tabs" out of the console sides. This will make removing the console lid easy yet the lid will stay in place quite nicely by slipping into the custom made channels made into the console sides.

GLOVE BOX CROSS SECTIONAL VIEW

Figure 16-20

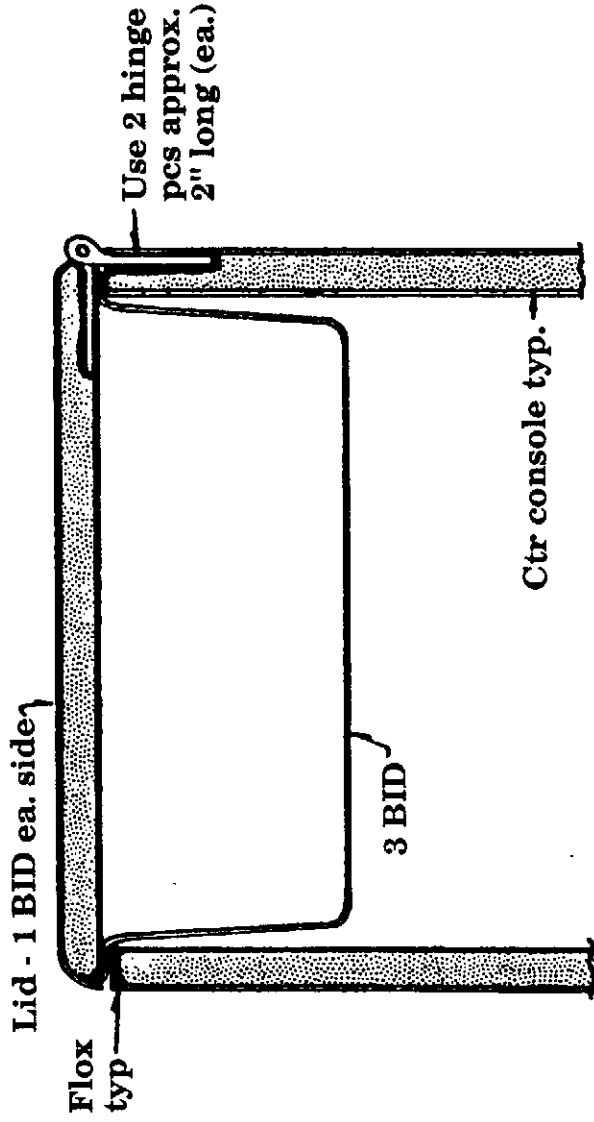

I. Side arm rest installations

Side arm rests are not required but they sure are comfortable and easy to install.

1. First sit in the cockpit with appropriate cushioning to simulate the upholstery and relative seating heights.

Take a book or anything similar and place it under your left elbow to simulate the ideal position for an arm rest. Now hold the control stick and pull it aft noting the angle of movement required of your left elbow. It's not horizontal at all but at an angle of about 15° (being higher in front than in the back).

When it feels about right, mark a pencil line on the side of the fslg to indicate this ideal position and angle of the arm rest. This line will indicate a "top surface" for the arm rest so you must calculate padding and base plate thickness when positioning the actual mounting bracket.

2. There are a lot of acceptable ways to attach an arm rest but probably the easiest and quickest is to simply cut a piece of 1" x 1" angle aluminum about 4" long per side. Drill a bunch of holes into one side for flox and also two small holes for a couple of pop rivets.
3. Pot the angle aluminum pieces onto the fslg and set them with the two pop rivets. The pop rivets will simply penetrate the inner skin and core of the fslg, not the outer skin.
4. Make a base plate that can be padded and upholstered. Use a piece of 1/4" plywood for this purpose. Cut it to the size you want the arm rest to be. It should be small so as not to get into your way when entering or exiting. Our arm rest measures 6" long by 1-3/8" wide and it could be somewhat smaller and still be very comfortable.
5. Simply use two small screws, entering from the underside to secure the wood base to the aluminum tab.

SIDE ARM REST

Figure 16-21

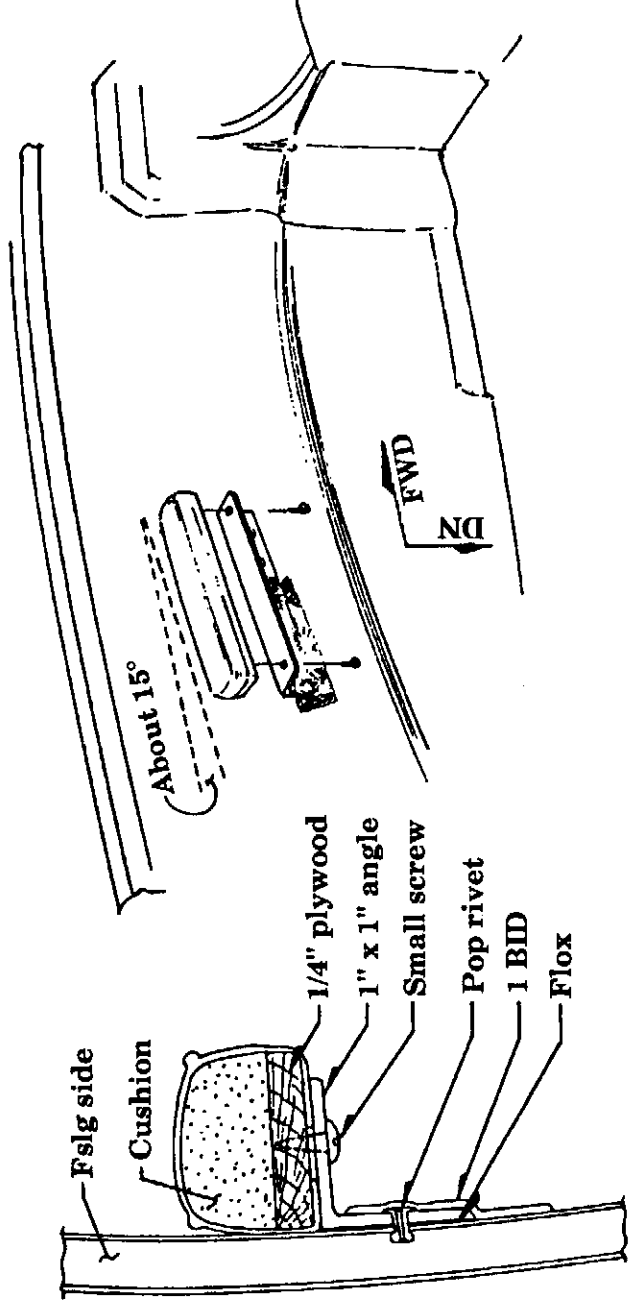

J. Shoulder strap installations

Shoulder straps, though not required are strongly recommended for safety. The "Y" type of shoulder strap is preferred. This type will therefore have less straps transitioning through the baggage area.

1. First make the upper brace for the top of the baggage bulkhead, this is where the shoulder straps will attach. See figure 16-22. Make a cardboard pattern that fits the fslg sides and in a manner similar to that used with the seat back bulkhead, tape the two cardboard sides together to form the accurate length of the upper brace panel.
2. Make the brace from 1/2" foam (or 3/8" honeycomb) with 2 BID per side. Insert the two phenolic pieces where the shoulder strap attach bolts will be located. See figure 16-23.

NOTE: This upper brace can also serve as a "hat shelf", see the suggested installation in figure 16-22. Due to its long moment arm, this area will have to be placarded for 5 lbs maximum (for CG reasons). Also check your particular weight and balance for accurate data on your aircraft.

SHOULDER STRAP ATTACHMENT

Figure 16-22

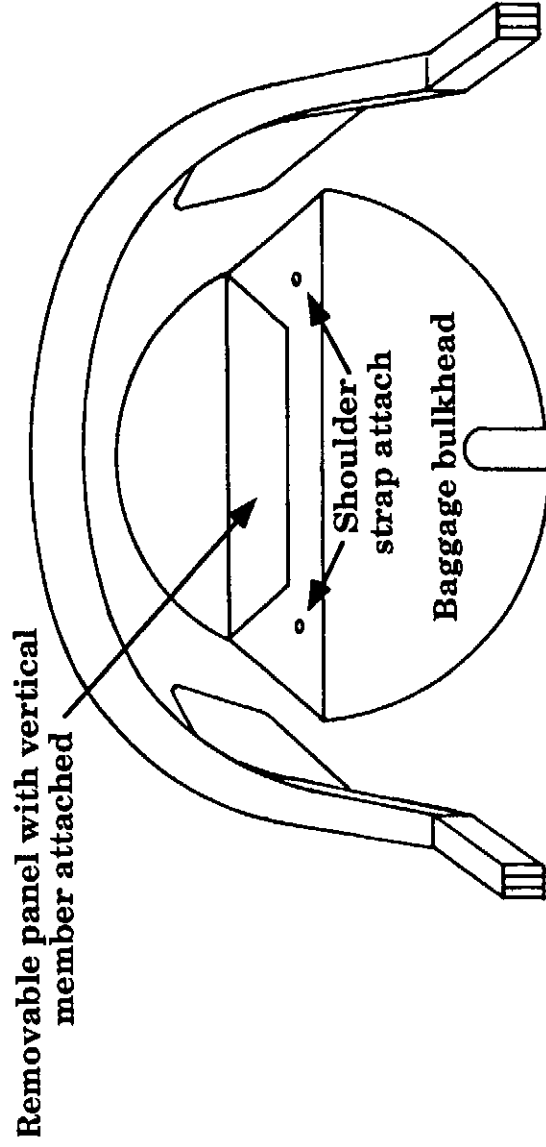

SHOULDER STRAP ATTACHMENT

Figure 16-23

VIEW AA
2 versions

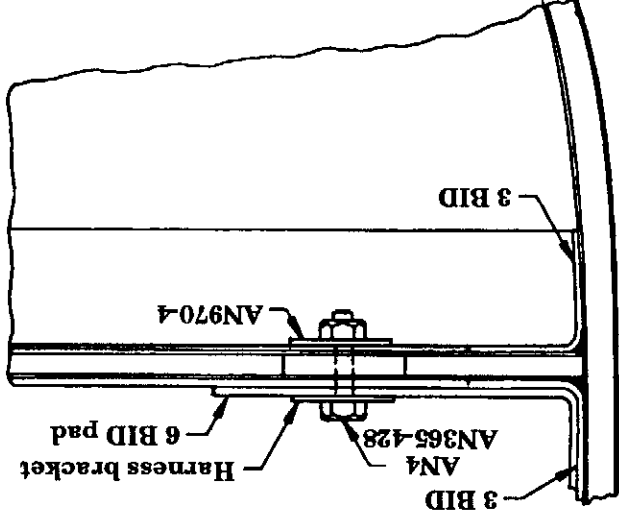
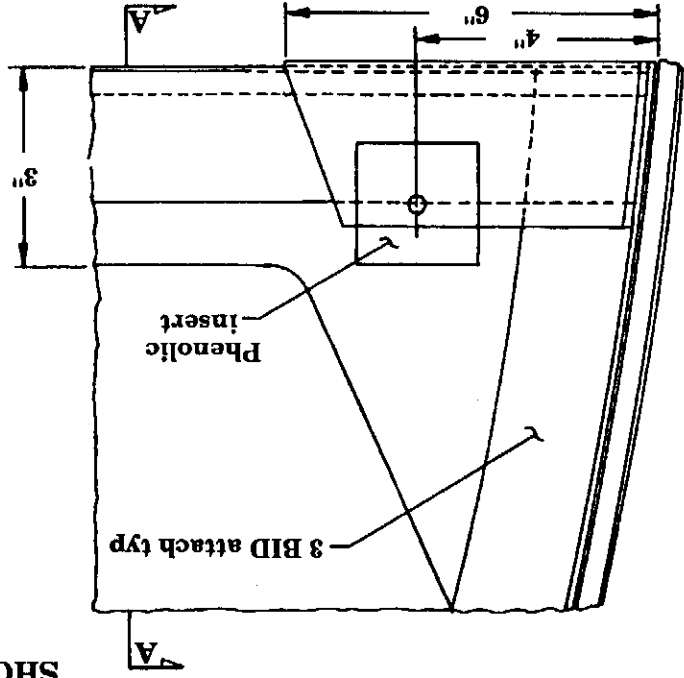
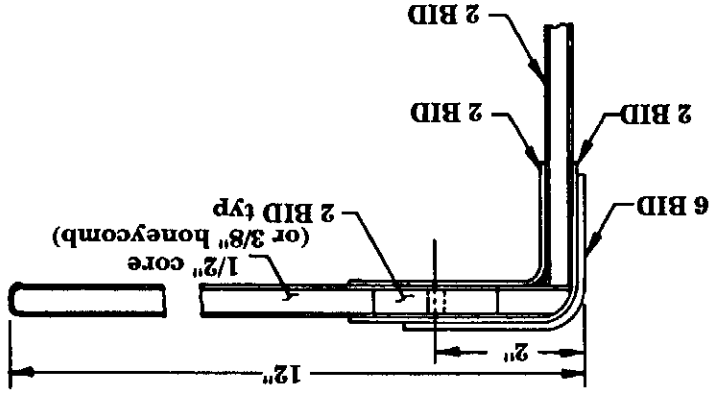
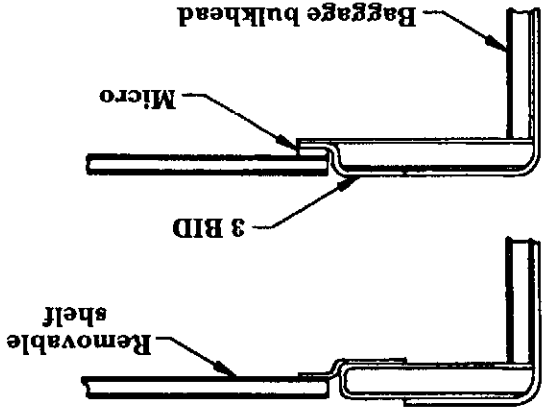

3. Use micro to pot the upper brace into position.
4. Secure it with 3 BID along the fslg sides both upper and lower plus 2 BID across the top of the intersection of baggage bulkhead to upper brace. This 2 BID should be on both fwd and aft sides. And at the same time, add the additional plies where the shoulder strap hard points are located, see figure 16-23.
5. Figure 16-23 shows two acceptable ways to fit a removable center portion which will complete the "hat shelf".
6. The hat shelf itself can be simply 1 BID over 1/4" foam. At the back edge, make a vertical bulkhead closeout to seal off the tail cone from the cabin area. This will also be simply a 1 BID layup over 1/4" foam core.
7. For removal of the vertical bulkhead, you have to hinge the piece onto the center portion of the hat shelf floor. Use two small 2" hinge sections in a manner similar to that of the glove box lid only permanently bond both sides of the hinges into their respective panels. Place a small tab vertically on the top of the fslg tail cone area so that you can hold the vertical panel up in position with a small velcro attachment from back of panel to the tab on the fslg. The tab can be made of a small 1/2" long 3 BID piece of angle. You may also need a small tab to hold the front of the panel down against the upper brace, use a small (1/2" x 1-1/4") piece of aluminum or a 3 BID piece of glass. Set it with one pop rivet into the fwd 3" wide section of the shoulder strap cross member. Then simply swing it over the front edge of the removable panel to hold the panel front down into its mating lip.



K. NACA duct installations (cockpit ventilation)

Cockpit ventilation is achieved best by installing two NACA ducts into the fslg. Neico Aviation has two popular vents available, see our options catalog. We prefer the simple plenum box NACA ducts as the other type is a bit delicate and do not seem to offer good longevity.

1. The recommended position for the NACA ducts is per figure 16-24. For position, what is important is that when you are seated in the cockpit, you should be able to see the duct under the instrument panel. If you can see it, it can see you (and thus blow air into your face if desired).

NACA DUCT POSITION

Figure 16-24

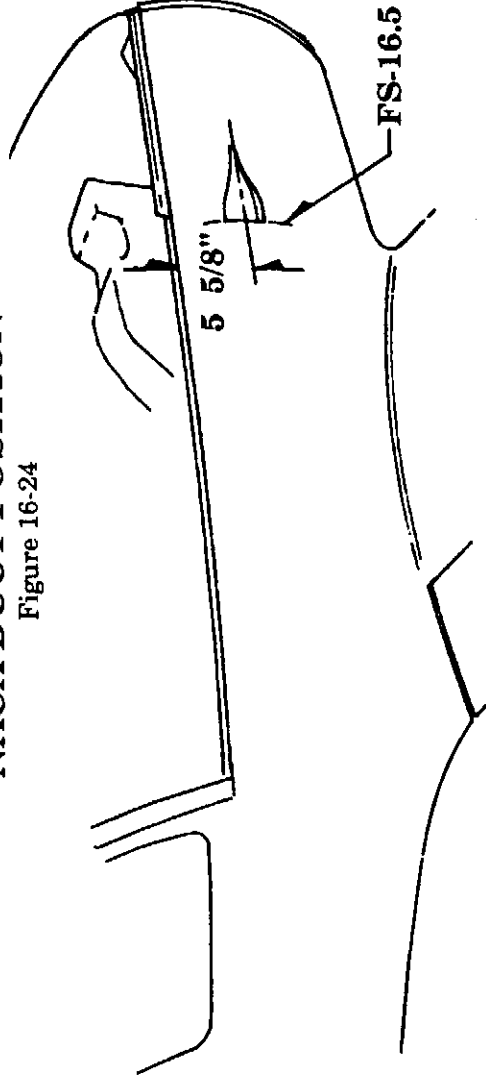

2. Use the full size pattern in figure 16-25 and position it onto the outside of the fslg according to the recommended positioning and also provided that it is in agreement with your particular cockpit orientation as determined by your seating position.
3. Use a sabre saw and cut all the way through the fslg.
4. Next, from the inside, enlarge the cut out so that the actual NACA duct can be bonded in from the inside and contact directly onto the outer skin plies. Leave about a 1/2" lip on the NACA duct itself. Use either epoxy/flox or better yet use structural adhesive to bond the NACA duct into position. Use pop rivets from the outside to hold it tight against the fslg skin when bonding into position. Allow to cure.
5. Next add a micro fillet around the inside against the honeycomb core that is exposed and follow up directly after with 2 BID all around the perimeter. Contact at least 2" onto the fslg and onto as much as possible of the NACA duct (up to about 1-1/2" maximum).

6. Now you can drill and install an eyeball vent or bond a short section of tubing onto the plenum box so as to be able to route a remote vent onto the instrument panel.
7. Neico Aviation has available two types of eyeball vents. One is the screw mount type that can be installed directly onto the plenum box of the NACA duct. The other can be panel mounted since it has a more decorative face panel with a rear attachment bezel. This unit can also be fitted with a custom plenum of its own that allows for a 3/4" hose connection. See the Options Catalog. With this combination, you can install two vents per side by simply attaching a short length of 3/4" tubing onto the top of the plenum box and routing a piece of 3/4" scat hose to the remote panel mounted vent. The lower center portion of the optional Lancair 320 instrument panel has a custom mounting position built into it.

NOTE: It is important to keep the edges of the NACA duct relatively sharp on the outside. This will help generate a vortex that slows the air, thus building pressure and making the duct most effective.

Page 16-39 and 16-40 are identical so that one may be removed and used as a full size template, while retaining manual content.

LANCAIR® 320FB

16-38

Chapter 16 REV. 0 / 11-1-91
COCKPIT INSTALLATIONS

Naca Duct Layout

Figure 16-25

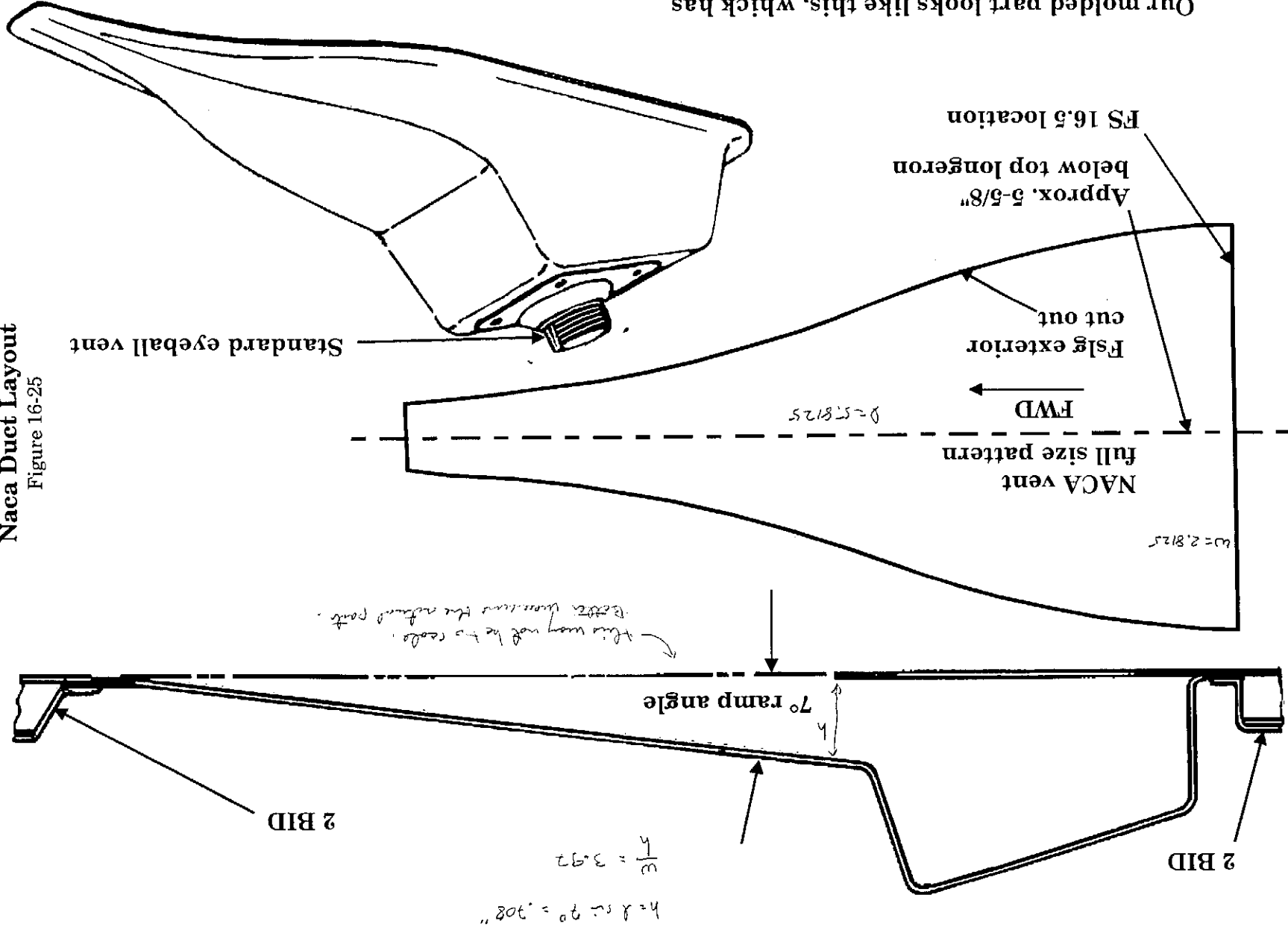

Standard eyeball vent

Our molded part looks like this, which has the provision for a direct mounting of the standard eyeball vent, as shown



LANCAIR® 320FB

Lancair International Inc. Copyright © 1991, Redmond, OR 97756

Chapter 16	REV.	A2/04/01/99
COCKPIT INSTALLATIONS		
16-39		

Naca Duct Layout

Figure 16-25

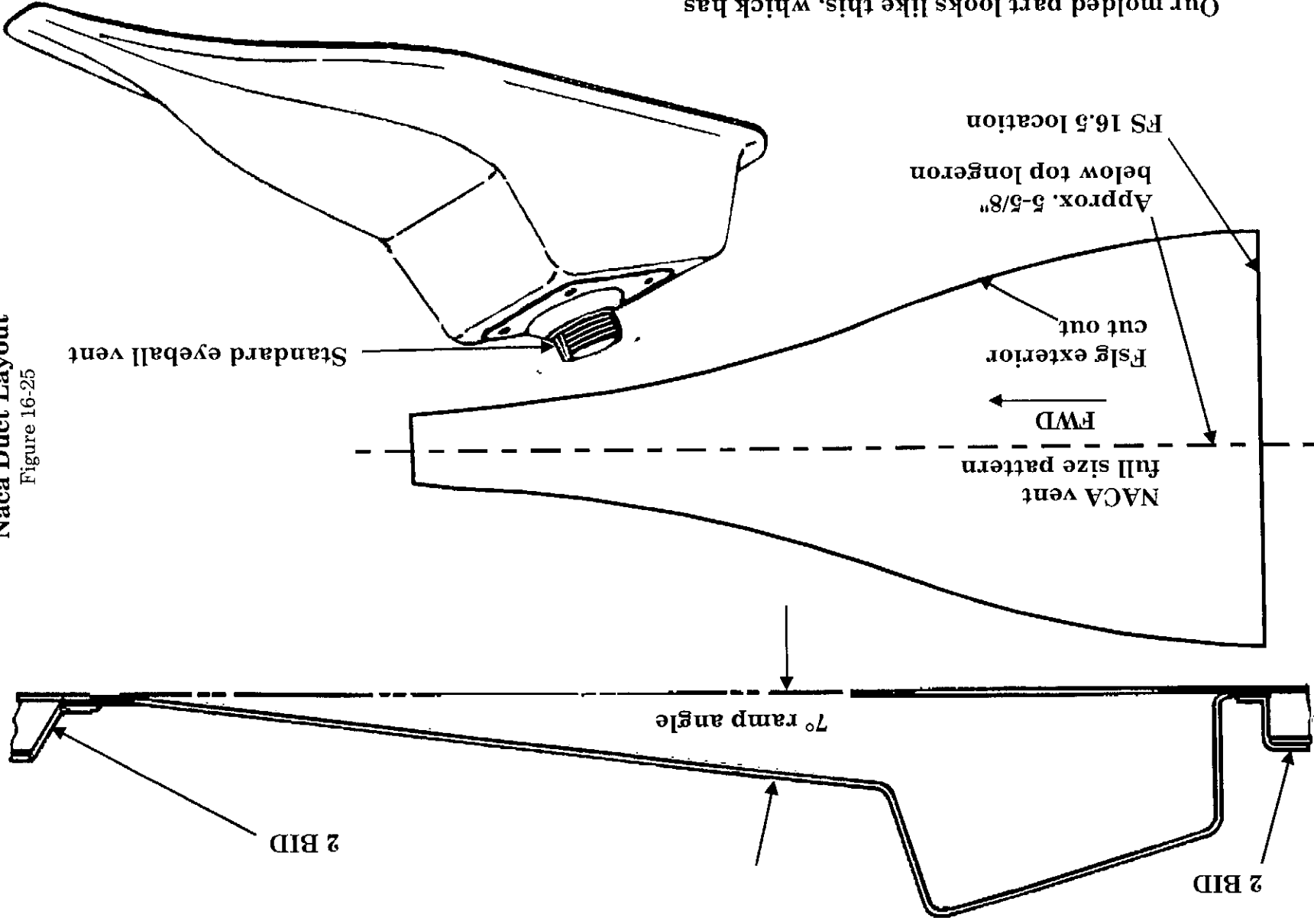

Standard eyeball vent

2 BID

2 BID

Our molded part looks like this, which has the provision for a direct mounting of the standard eyeball vent, as shown

LANCAIR® 320FB

16-40

Chapter 16 REV. A2/04/01/99
COCKPIT INSTALLATIONS

Pitot / static installations

There are many acceptable approaches to the installation of the pitot and static system. Much depends on your degree of preferred sophistication and intended flying uses. (I.e., for serious IFR flying you should have a heated pitot tube with alternate static air switching capabilities.) We will show two of the many possible installations.

L. Home made pitot tube installation

1. This installation can be placed just inside of the BL-50 rib thus eliminating a connection with wing removal. It is just marginally outside the prop wash so you will get a little buffet on the airspeed needle when on the ground due to the ground effect. In the air, it works quite satisfactorily. You can however locate this at an outbd wing location and make the connection with wing removal / installation. See figure 16-26.

PITOT TUBE HOMEMADE INSTALLATION

Figure 16-26

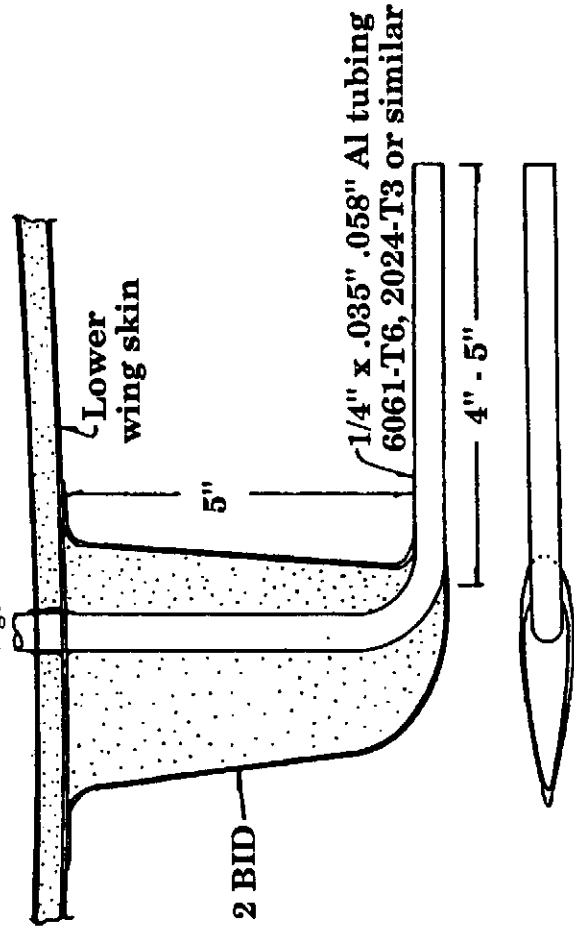

M. AN5812 Standard pitot tube installation

1. A standard heated pitot tube can also be a simple installation and looks perhaps a bit more professional. The AN5812 heated unit is available from a variety of sources (including Neico - be sure to use the correct suffix when ordering - the AN5812-12 is 12 volt, and the AN5812-24 is 24 volt) and can be installed quickly.
2. Cover the base of the unit with wax or plastic tape as a release then take a piece of scrap plywood or equiv. and cut a small hole in it to allow the leads to protrude through.
3. Check the approximate angle of the unit against the lower wing skin and set the plywood such to match that when the unit is placed on top. See figure 16-27. A few dabs of hot or instant glue will hold it in place temporarily. Cover the wood base with release as well.
4. Now lay up a 4 BID piece around the base. Roll up onto the pitot unit about 1/4" past the mounting screw holes. Roll onto the wood base form by about 1". Allow to cure.
5. After cure, pop the base off and pull the pitot unit out of the now formed attach bracket. It will pull out a bit hard, but it WILL pull out.

Trim the bracket and bond it onto the bottom of the wing panel having cut a clearance hole for the pitot unit into the skin. Use epoxy/flox to attach the bracket and fair it in with micro later. Drill through and use the supplied screws to hold the pitot unit into the fiberglass mount.

PITOT TUBE COMMERCIAL, HEATED TYPE INSTALLATION

Figure 16-27

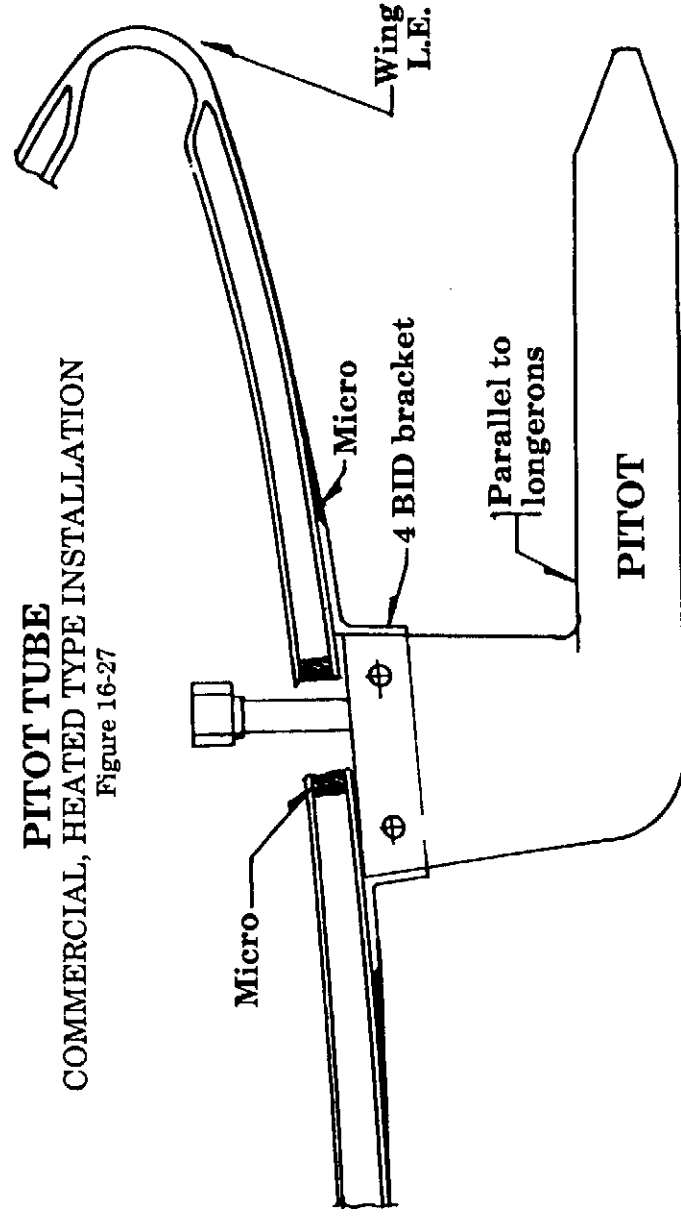

NOTE: The pitot tube should be positioned parallel with the level line of the fslg and just behind the leading edge of the wing.

6. Run a piece of aluminum line from the pitot unit through the D section of the wing into the cockpit and up behind the instrument panel. Secure it at the panel and fslg side with a couple pieces of 1 BID (each about 2" long will be sufficient).

CAUTION: Do not secure this aluminum line (from the pitot tube to back of instrument panel) until the canopy mechanism is installed since you will have to be sure to clear all of that mechanism with the line.

N. Static port installation

1. This static port is the most susceptible to instrument reading errors since it is not easy to accurately locate a position on the side of the fslg that is indeed *static*. Since the Lancair is not a "slab sided" airplane like so many other types, pressures are constantly changing as they move along the fslg. We have located a position that is accurate, but it has a relatively small "window of acceptability", i.e., a little bit off one way or another can produce a sizable change in pressures.

One way around the potential problem is to use a "Shark Fin" type of pitot / static unit like the Kollsman Pitot Static Tube. This will have the static line pick up in it and must be installed on the outbd leading edge of the wing. A bracket (made of fiberglass) would be made similar to that described for the heated pitot.

2. For the side mounted static source, locate the position (FS-80) per figure 16-28 and drill a small hole (#40 bit size) all the way through the fslg. We've always installed them on the right side. If you want to eliminate side slipping errors, then install one on each side and "T" them together.

STATIC PORT LOCATION

Figure 16-28

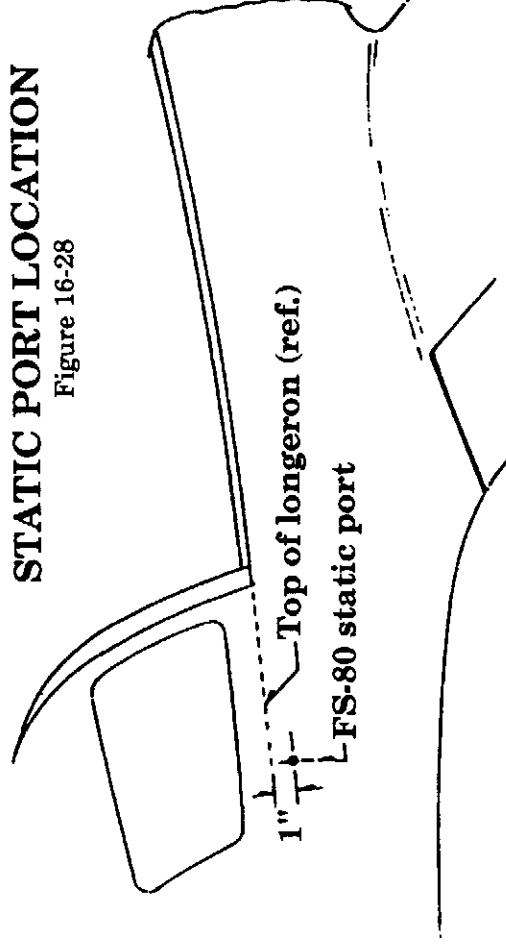

3. Two acceptable methods of implanting a pick up are shown in figure 16-29. Either will work well. Pot the tube section or Nylo-Seal fitting into the fslg side having first cut back the honeycomb and filled the area in with micro. Allow to cure. While it is curing, slip the drill bit back into the hole and push it through so as to open the hole that probably got plugged with micro. If you wax the drill bit you can simply leave it in the hole and that's it. Or, you can simply come back later and drill through once again.

STATIC PORT INSTALLATION

Figure 16-29

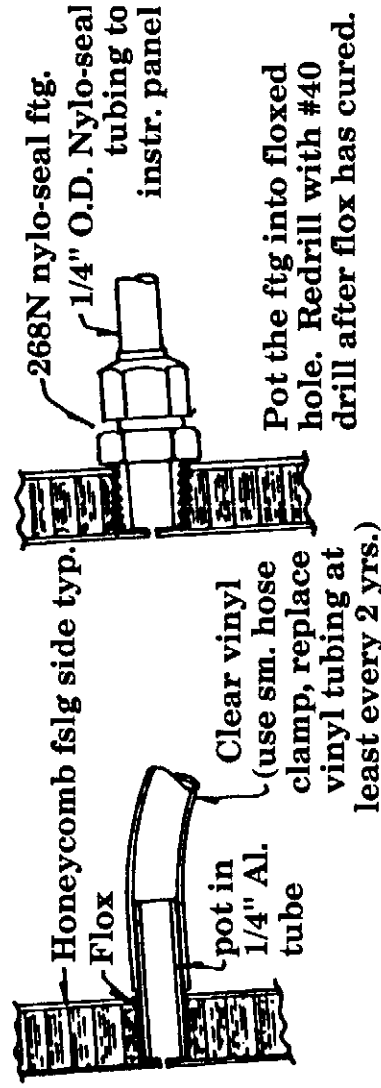

WARNING: The static port line, as it leaves the fuselage side, should angle upward first before heading down for the console where it will route to the panel. This is to prevent excess amounts of water from entering the line. (Water is not likely to run up hill.) A water trap could also be installed.

NOTE: It is a good idea to install a water trap into the static tube system at the first low point (nearest to the fslg origin). This is commonly a plastic bubble that allows water to be collected there and not continue on up into the instrument or plug the line which would make for very inaccurate airspeed, altimeter and VSI readings. It can be checked regularly and emptied as required. Many planes found at Oshkosh will not have this provision but it certainly must be recommended.

We've found that the company Lancairs do not tend to get water in the static line unless they're sitting in a windy raining condition where the wind blows on the appropriate side of the fuselage. If that happens, the static line could quickly fill up. Thus a collector is recommended. A collector bulb could be located just behind the seat, before the line routes up into the center console.

THIS CONCLUDES CHAPTER 16.

Lancair® 320FB

Lancair International Inc. Copyright © 1991, Redmond, OR 97756

16-45

Chapter 16 REV. 0 / 11-1-91

COCKPIT INSTALLATIONS